

# ACM Family

System Installation & Configuration



<b>1</b>	<b>Introduction .....</b>	<b>5</b>
1.1	About this Document.....	5
1.2	Publication Log .....	5
1.3	Related Documentation .....	5
1.4	DNV Type Approval Regulations.....	5
1.5	ACM Test Reports.....	5
<b>2</b>	<b>ACM System Overview .....</b>	<b>6</b>
2.1	General .....	6
2.2	System Architecture of ACM Family.....	7
2.2.1	ACM main system rack.....	7
2.2.2	Field equipment .....	8
2.2.3	Supplementary systems.....	9
<b>3</b>	<b>System Functions .....</b>	<b>10</b>
3.1	Marine Emergency and Safety Applications .....	10
3.1.1	Overview .....	10
3.1.2	Two-way voice communication .....	11
3.1.3	Public Address and General Alarm .....	12
3.1.4	Handsfree two-way communication (Talk-Back).....	15
<b>4</b>	<b>Hardware Installation Instructions .....</b>	<b>16</b>
4.1	General Environment Requirements.....	16
4.2	System Rack Mounting .....	16
4.2.1	ACM-M-A-V2 / ACM-M-D-V2 .....	16
4.2.2	ACM-48-V10 .....	16
4.2.3	ACM-M-D/IP72 / ACM-M-D/IP96 .....	16
4.2.4	ACM-144-V10 / AACM-144-V10 .....	17
4.3	Installing Feature Boards .....	17
4.3.1	Hot-plug .....	17
4.3.2	AMC-IP - AlphaCom Module Controller Board.....	17
4.3.3	Board positions .....	18
4.4	Connection Terminals .....	18
4.4.1	ACM-M-A-V2 and ACM-M-D .....	18
4.4.2	ACM-48-V10 .....	20
4.4.3	ACM-144-V10 and AACM-144-V10 .....	20
4.4.4	ACM-M-D/IP72 / ACM-M-D/IP96 .....	21
4.5	Power Supply .....	21
4.5.1	ACM-M-A-V2 / ACM-M-D .....	21
4.5.2	ACM-48-V10 / ACM-144-V10 / AACM-144-V10.....	21
4.5.3	ACM-M-D/IP72 / ACM-M-D/IP96 .....	22
4.5.4	Cable dimensions .....	22
4.6	Line Connection Module (LCM) .....	23
4.6.1	24 VDC power.....	24
4.6.2	Subscriber lines .....	24
4.6.3	RCO - Remote Control Outputs.....	24
4.6.4	RCI - Remote Control Inputs.....	25
4.6.5	PA Connection.....	25
4.6.6	PA amplifier with chime, without monitor.....	26
4.6.7	Radio / Walkie-talkie Interface .....	27
4.6.8	Audio input - 6 channels .....	28
4.7	ACM-IP Patch Panel & I/Os .....	28
<b>5</b>	<b>Programming &amp; Cable Reference List.....</b>	<b>29</b>
5.1	Station and User Information .....	29
5.1.1	Station information .....	29
5.1.2	Programming .....	30
5.1.3	Terminal connections .....	30
5.1.4	Additions .....	31
5.2	Integrated PA Interface .....	31
5.3	IP Configuration .....	32
5.4	Trunk Lines .....	32

<b>6</b>	<b>Programming Overview.....</b>	<b>33</b>
6.1	AlphaWeb - Getting Started .....	33
6.1.1	Connecting to ACM using AlphaWeb .....	34
6.1.2	Saving and applying changes .....	34
6.2	AlphaPro - Getting Started .....	35
6.2.1	PC setup .....	35
6.2.2	Insert the HW dongle .....	35
6.2.3	AlphaPro Menu Structure.....	35
6.2.4	Creating a New Network and Exchange .....	35
6.2.5	Data communication .....	36
<b>7</b>	<b>Programming Guide.....</b>	<b>37</b>
7.1	Programming Overview .....	37
7.2	Perform Cold Start .....	37
7.2.1	Cold start procedure .....	37
7.2.2	Cold start AMC application only (retain IP settings)....	37
7.3	Configure IP Address .....	38
7.4	Enter License Key .....	39
7.5	Configure User Settings.....	39
7.5.1	General user settings .....	39
7.5.2	Program different class of service for users.....	42
7.6	Handsfree Two-Way Conversation (Talk-Back) .....	43
7.6.1	Overview .....	43
7.7	Configuring Public Address and General Alarm.....	44
7.7.1	Overview .....	44
7.7.2	Configure audio interface from SPA-V2 to ACM .....	45
7.7.3	Configure ACM PA zones.....	47
7.7.4	Configure audio interface ACM to SPA-V2.....	48
7.7.5	Feedback – Intercom as PA panel .....	50
7.7.6	Delayed PA Message - Recall.....	50
<b>8</b>	<b>ACM System Racks Specifications .....</b>	<b>51</b>
8.1	ACM-M-A-V2.....	51
8.2	ACM-M-D .....	51
8.3	ACM-48-V10 .....	52
8.4	ACM-144-V10 .....	52
8.5	AACM-144-V10.....	53
8.6	ACM-M-D/IP72 & ACM-M-D/IP96 .....	53
8.7	Environmental Requirements.....	54
<b>9</b>	<b>Appendix A - Example Configuration Diagrams .....</b>	<b>55</b>
9.1	Two-Way Communication .....	55
9.2	Public Address on Conventional Vessels.....	56
9.3	Integrated Public Address and General Alarm .....	57
9.4	Drawing Symbols .....	59
<b>10</b>	<b>Appendix B - ACM System Components .....</b>	<b>60</b>
10.1	ACM Main System Racks .....	60
10.2	ACM Field Equipment.....	61
<b>11</b>	<b>Appendix C - Internal Power Wiring in System Racks .....</b>	<b>63</b>
11.1	ACM-M-A-V2.....	63
11.2	ACM-M-D-V2 .....	63
11.3	ACM-48-V10 .....	64
11.4	ACM-144-V10 .....	64
11.5	ACM-M-D/IP72.....	65
11.6	ACM-M-D/IP96.....	65
<b>12</b>	<b>Appendix D - ACM Call Types .....</b>	<b>66</b>
<b>13</b>	<b>Appendix E - Audio Messaging .....</b>	<b>67</b>
13.1	Stored Voice Messages .....	67
13.1.1	Message identification .....	68
13.1.2	ASVP software module .....	68
13.1.3	ASVP board .....	68

13.2	Customized Message Upload .....	69
13.2.1	Upload messages from AlphaWeb .....	69
13.2.2	Record message from a station .....	70
13.2.3	Licensing .....	71
13.2.4	Supported audio file formats .....	72
13.3	Recall .....	72
13.3.1	Directory numbers .....	72
13.3.2	User interface .....	73
13.3.3	Optional settings .....	73
13.3.4	Simultaneous recall operations .....	74
13.3.5	Hardware and software requirements .....	74
13.4	Auto-Attendant .....	74
13.4.1	Configuration .....	74
13.4.2	Hardware and license requirements .....	75

## Figures

Figure 1	Configuration example .....	6
Figure 2	The AlphaCom XE server/exchange family .....	8
Figure 3	Basic PA & GA for conventional vessels .....	14
Figure 4	Basic PA & GA for passenger vessels .....	14
Figure 5	DECT and UHF interface .....	15
Figure 6	Clearance Dimensions for ACM-M-A & ACM-M-D cabinets .....	16
Figure 7	Clearance Dimensions for ACM-48-V10 cabinet .....	16
Figure 8	Clearance Dimensions for ACM-M-D/IP72 & ACM-M-D/IP96 cabinets .....	16
Figure 9	Clearance Dimensions for ACM-144-V10 cabinet .....	17
Figure 10	Hot-plug .....	17
Figure 11	Board positions in AlphaCom XE7, XE20, XE26 .....	18
Figure 12	Terminals in ACM-M-A-V2 .....	19
Figure 13	Terminals in ACM-M-D .....	19
Figure 14	Terminals in ACM-48-V10 .....	20
Figure 15	Terminals in ACM-144-V10 & AACM-144-V10 .....	20
Figure 16	ACM-M-A/D Power connection .....	21
Figure 17	ACM-M-D/IP72 / ACM-M-D/IP96 Power connection .....	22
Figure 18	24 VDC connections .....	24
Figure 19	Telephone and intercom line connection example .....	24
Figure 20	RCO 1-6 connection & interface to AlphaCom XE7 .....	25
Figure 21	RCI closing contact connection .....	25
Figure 22	Audio input connection .....	28
Figure 23	Connect PC to Eth0 .....	34
Figure 24	Cold start .....	37
Figure 25	Cold start to load default database .....	37
Figure 26	Cold start and keep IP settings .....	37
Figure 27	Integrated PA & GA Overview .....	44
Figure 28	Example configuration - Two-Way communication .....	55
Figure 29	Example configuration - Public Address on conventional vessels .....	56
Figure 30	Example configuration of Integrated PA & GA - Loop A .....	57
Figure 31	Example configuration of Integrated PA & GA - Loop B .....	58

## Tables

Table 1	DNV requirements .....	10
Table 2	Board Positions .....	18
Table 3	Power and cable values .....	23
Table 4	Switch settings for PA monitoring .....	26
Table 5	Switch settings for radio monitoring .....	28
Table 6	Station and user information example .....	29
Table 7	Integrated PA interface example .....	31
Table 8	IP Configuration example .....	32
Table 9	Trunk lines example .....	32
Table 10	Call Setup Priority .....	41

# 1 Introduction

---

## 1.1 About this Document

The scope of this document is to provide a system description, installation procedures, and service instructions for the VINGTOR ACM Communication Systems.

The document consists of the following main parts:

- System overview
- System functions
- HW installation guide
- Programming guide
- Specifications

## 1.2 Publication Log

Rev.	Date	Author	Comments
1.1	2010-12-15	HKL	Preliminary
2.0	2011-02-04	HKL	Published
3.0	2013-02-01	HKL	Draft
3.1	2017-12-08	SEN	Changes page 15

## 1.3 Related Documentation

Doc. no.	Documentation
A100K10792	User Guide for ACM Emergency Functions
A100K10648	Programming ACM Emergency Functions
A100K10649	Data Network Guidelines for Ships
A100K10430	ACM-M-A-V2 ACM Telephone System
A100K10369	SPA-V2 PA & GA System Manual
A100K10370	SPA-V2 PA & GA Configuration & Installation Manual
A100K10371	SPA-V2 PA & GA User Manual
A100K10805	AlphaCom XE Installation, Configuration & Operation
A100K10390	SIP GSM Gateway MV-370
A100K10333	SIP Analog Gateway AudioCodes MP-114/MP-118
A100K10590	Billing System Configuration Guide
A100K10610	LCM - Line Connection Module
A100K10652	IP DECT Installation & Configuration
A100K10777	IP DECT Quick Configuration
A100K10788	IP Master Station Installation & Configuration
A100K10935	IP Master Station Getting Started Guide

## 1.4 DNV Type Approval Regulations

- DNV requirement for Internal Communication on ships, Doc. "Rules for Ships. January 2006 Pt.3 Ch.3 Sec.11"

## 1.5 ACM Test Reports

- Technical Report on ACM system EN60945 compliance V1.0
- NEMKO Technical Report E06067.00 – ACM – June 2006
- Report no 2000-1366 Type Approval Testing AlphaCom M (ACM M/MP). Tested according to DNV Certification Notes 2.4 – May 1995. Additional test DNV Certification Notes 2.4 draft Dec. 1999

## 2 ACM System Overview

### 2.1 General

The VINGTOR ACM system is an integrated communication system specially designed for use on board marine vessels.

ACM provides system solutions that will unite and strengthen a vessel's safety systems by offering excellent on-board communication, remote control of signal units, and alarm distribution with voice control in emergency situations. The system supports marine emergency functions for:

- Two-way communication
- Handsfree two-way communication (talk-back)
- Public Address for conventional vessels
- Public Address for passenger vessels
- Integrated Public Address and General Alarm

The unique 18.5 kHz audio bandwidth ensures no misunderstandings when important voice messages are distributed. Audio programmes and communication via the Public Address part of the system comes through with a superior sound quality. In addition, the system supports a wide range of supplementary services such as:

- External telephone interface
- Billing of external calls
- General PBX functions
- DECT cordless telephones
- Data networking and cable distribution
- Paging
- Music entertainment
- Integration with iPBX

The VINGTOR ACM system supports a wide range of conventional, IP, SIP, and wireless terminals made for the marine environment.

The ACM conventional and IP intercom stations support the VINGTOR integrated telephone, talk-back, Public Address and General Alarm solution. This provides a cost efficient solution for covering areas where PA and GA is required onboard the ship. In addition, the ACM intercom panels provide a single user interface for PA, talk-back and telephony, thereby simplifying operations onboard.



Figure 1 Configuration example

Easy programming from a PC allows you to customize the system to suit your own requirements. A standard PC is required for configuration and programming.

The system provides advanced monitoring and supervision functions, allowing fast detection, identification and fault repair. All stations, exchange cards, and software processes are continuously monitored to detect faults quickly. When a fault is detected, the system can report the fault to:

- Display on administrator intercom station
- Pager
- Lamp
- Local log file
- External system management application like HP Openview
- E-mail

## 2.2 System Architecture of ACM Family

The VINGTOR ACM system consists of:

- ACM main system rack
- ACM field equipment.

In addition, an ACM installation may consist of supplementary systems:

- SPA-V2 Public Address system
- Data network system

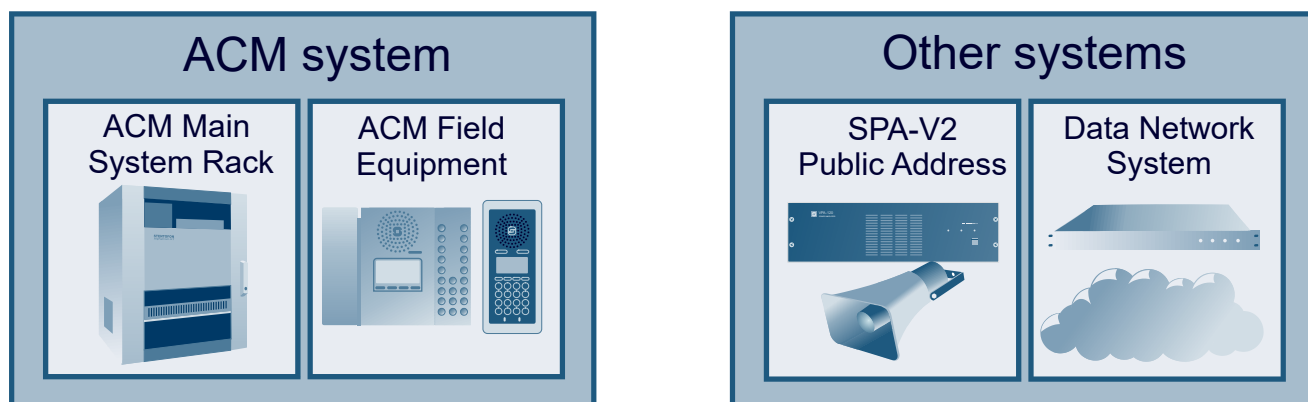

### 2.2.1 ACM main system rack

The ACM main system rack is the central unit in the whole system. It connects all field equipment and provides all main central services. Several system racks can be connected via the data network.

The VINGTOR ACM family includes the following main system racks:

- ACM-M-A-V2 (AlphaCom XE7)
- ACM-M-D-V2 (AlphaCom XE7)
- ACM-M-D/IP72 (AlphaCom XE7)
- ACM-M-D/IP96 (AlphaCom XE7)
- ACM-48-V10 (AlphaCom XE20)
- ACM-144-V10 (AlphaCom XE26)
- AACM-144-V10 (AlphaCom XE26)

For a complete list of system rack components, see *Appendix B - ACM Main System Racks*.

The different ACM systems are built around a STENTOFON AlphaCom XE server/exchange. The AlphaCom XE is an advanced communication

server designed to meet the growing needs of internal and external communication onboard marine vessels. The exchange features advanced functions such as 1-bit audio technology (18.5 kHz audio), IP, Web services, and a wide range of integration options, etc.

AlphaCom XE is a modular platform, supporting IP as well as analog telephones and networking. This modularity and flexibility is used to bundle the product into different system packages. These system packages satisfy the requirements of all kinds of marine vessels, ranging from small conventional vessels to large advanced ships.

In addition to the intercom exchange, the system rack consists of a steel cabinet and a main distribution panel to connect field equipment as well as electrical power.

For a detailed description of the AlphaCom XE server/exchange, see *A100K10805 AlphaCom XE Installation, Configuration & Operation Manual*.

### **STENTOFON AlphaCom XE**

The STENTOFON AlphaCom XE intercom exchange is the heart of the ACM rack. The exchange manages all telephones, intercoms and devices connected to the system rack and supports a wide range of PABX and emergency communication features.

The STENTOFON AlphaCom XE intercom exchange comes in three different sizes. This is the AlphaCom XE7, AlphaCom XE20 and AlphaCom XE26. These intercom exchanges use:

- Same line and interface board (ASLT) for PA and intercom units.
  - 6 lines and one conversation channel per board
- Same telephone line interface board (ATLB-12) for analog telephones.
  - 12 telephone lines per board
- Same processor board (AMC-IP)
- Same software and functions (AMC software)
- Same set of conventional intercom stations are supported
- Same set of IP intercom stations are supported

### **The units have the following differences in Line capacity:**

**AlphaCom XE7** supports maximum 6 line and interface boards.

- 6 x ASLT boards supports a total of 36 stations and 6 simultaneous loudspeaking calls
- 6 x ATLB-12 boards supports 72 analog telephones.

**AlphaCom XE20** supports maximum 18 line and interface boards.

- 18 x ASLT boards supports a total of 108 stations and 18 simultaneous loudspeaking calls
- 18 x ATLB-12 boards supports 216 analog telephones.

**AlphaCom XE26** supports maximum 24 line and interface boards.

- 24 x ASLT boards supports a total of 138 stations and 24 simultaneous loudspeaking calls
- 24 x ATLB-12 boards supports 216 analog telephones.

All exchanges can use any mix of ASLT and ATLB-12 boards.



*Figure 2 The AlphaCom XE server/exchange family*

### **2.2.2 Field equipment**

The ACM system includes the following types of field equipment:

- Conventional analog intercom stations
- IP intercom stations



- Analog telephones
- Signal units
- Loudspeakers

See *appendix B - ACM Field Equipment* for a complete list of ACM field equipment.

### **Conventional intercom station**

The conventional intercom stations support the following capabilities:

- Two-way communication
- Broadcast of PA/GA
- PA panels
- Talk-back substations (Only VMP-503 and VMP-530 including accessories)
- Talk-back main station (Only VMP-430 including accessories)

### **IP intercom stations**

The IP intercom stations support the following capabilities:

- Two-way communication
- Broadcast of PA/GA
- PA panels
- Talk-back main station (Only IP Flush Master Station including accessories)

### **Analog telephones**

The analog telephones support the following capabilities:

- Two-way communication

### **Signal units**

The signal units are used in noisy areas to provide visual indication of calls and louder ringing (buzzer) signals.

### **Loudspeakers**

- The loudspeakers are connected to intercom stations or intercom line points.

## **2.2.3 Supplementary systems**

### **VINGTOR SPA-V2 (Public Address system)**

The SPA-V2 Public Address system is integrated into the overall solution to provide Public Address coverage using 100V speaker loops in areas where it is impractical to provide PA/GA coverage using intercom stations and in areas where redundant PA/GA coverage is required.

The SPA-V2 system is type-approved by DNV as a Public Address and General Alarm system.

### **Data network system**

The data network system is used to provide network connectivity between the ACM main system rack and IP intercom stations.

For information on how to implement the data network, see *A100K10649 Data Network Guidelines for Ships*.

# 3 System Functions

## 3.1 Marine Emergency and Safety Applications

### 3.1.1 Overview

Table 1 provides an overview of the safety and emergency functions that are required at different locations onboard a marine vessel.

Explanations: N = "Nice to have" X = Class Requirements # = Alternative PA or GA A = Alternative power source	1A1 Always required		ADDITIONAL CLASS / REQUIREMENTS TO - 1A1												
			Fishing vessel		OPASV	E0	DYNPOS	NAUT AW / NAUT OC				NAUT OSV			
Environments	INT	PA	GA	INT	GA	INT	INT		INT	INT	TB	VSP	PA	INT	
<b>Bridge and Control Rooms/operation room</b>															
Engine control room	x	x	x		#						x	x			
Cargo control room	N	x	x		#					x	x			x	
DP Control Consoler	N	x	x		#				x	x					
Radio desk	N	N	N		#					x				x	
Bridge	x	x	x		#							x			
Bridge wings	N	N	N		#					x	x				
Operation room (i.e ROV / Seismic)	N	x	x		#					x				x	
<b>Accommodations</b>															
Crew Cabins	N	#	#		#					x			x	x	
Engineer Cabins	N	#	#		#			x		x			x	x	
Officer Cabins	N	#	#		#					x			x	x	
Captain cabin	N	#	#		#					x		x	x	x	
Chief Eng. Cabin	N	#	#		#			x		x		x	x	x	
Bedrooms	N	#	#		#					x			x	x	
Cabin bathrooms		#	#		#								x		
Office	N	x	x		#			x		x				x	
Mess room	N	x	x		#					x				x	
Galley	N	x	x		#					x				x	
Conference room	N	x	x		#										
Corridors		x	x		#										
Staircase		x	x		#										
Gym	N	x	x		#										
Wardrobe	N	x	x		#										
Hospital	N	x	x		#					x				x	
Electrical workshop	N	x	x		#					x				x	
Dayrooms	N	x	x		#			x		x				x	
Elevator	N	x	x		#										
Fire Station	N	x	x		#										
Instrument room	N	x	x		#			x		x				x	
Switchboard rooms	N	x	x		#			x		x				x	
DP Control Center	N	x	x		#					x				x	
<b>Engine rooms and other noisy areas</b>															
Engine room	x	x	x		#					x				x	
Steering gir	x		x		#					x	x	x		x	
Bow thrust	x		x		#					x				x	
Emergency maneuvering stand	x		x		#					x				x	
Emergency generator room	N		x		#					x				x	
Engine work shop	N	x	x		#					x				x	
Moon pool	N	x	x		#					x				x	
Pump room	N		x		#					x				x	
<b>Open deck area</b>															
Deck workshop	N	x	x		#					x				x	
Mooring positions fwd / aft / mid ship	N		x		#					N	x			N	
Life boat stations / Embarcation	x	x	x		#					x				x	
Deck crane position	N	x	x		#					x				x	
Winch	N	x	x		#					N				N	
Muster station	x	x	x		#					x				x	
Side Opening on tweendeck					x										
Stern					x										
Other working positions		x	x					x		x				x	

Table 1 DNV requirements

The ACM system supports the following marine emergency and safety applications:

- Two-way voice communication
- Handsfree two-way communication (talk-back)
- Public Address for conventional vessels
- Integrated Public Address and General Alarm for conventional vessels
- Public Address for passenger vessels

The ACM system supports the following supplementary applications:

- External telephone interface
- Billing of external calls
- General PBX
- DECT cordless telephones
- Data networking and cable distribution
- Paging
- Music entertainment

### **3.1.2 Two-way voice communication**

The ACM system supports two-way voice communication according to marine requirements.

The two-way communication is handled by the AlphaCom XE intercom module within the ACM racks. The following marine regulatory requirements are supported:

- Special purpose stations
- Priority
- Communication to noisy areas
- Volume control
- Capacity

#### **Special purpose stations**

The ACM system supports a set of special purpose stations for different ship environments, including:

- Bridge and Console stations
- Watertight stations
  - Stations must have a rating of IP56 for outdoor environments. ACM IP stations must therefore be mounted in watertight housings.
- Desktop stations

#### **Priority functions**

The ACM system supports two types of priority functions:

- Busy override
- Call priority

#### **Busy override**

ACM stations can be configured to enable busy override. When these stations call a busy station, the user can dial a service code to set up the call. The ongoing conversation will be cancelled.

By default, no stations are configured with busy override enabled. It is usual to configure the stations at the bridge and in the captain's cabin with busy override.

### **Call priority**

ACM stations can be configured to have different call priorities.

Call priority has four levels:

- Alarm
- High
- Normal
- Low

If a call meets a resource congestion, e.g. no available channels, the station's priority is checked. If there is a conversation between stations with lower priority in the system, the lower priority call will be released and the higher priority call is set up.

An alarm call will also break through if the called user is busy.

### **Communication to noisy areas**

The ACM system supports a set of functions to handle calls to noisy areas.

#### **Light signaling**

The station in the noisy area can be supported by a light signal.  
- When a call is placed to the station, the light will flash.

#### **Industrial headset**

The station in the noisy area can have an industrial headset, thereby reducing disturbing noise.

#### **Loudspeaking calls**

If the system shall support loudspeaking calls to a noisy area, an external horn loudspeaker can be installed using a VMP-530 station including a 10 W audio amplifier for the loudspeaker.

To control the speech direction towards the noisy area, the remote user can use the push-to-talk key when talking. Using this key will also increase the volume at the remote end.

### **Volume control**

It is possible to configure the sound pressure level for each ACM station according to requirements for the location where the station is placed. The user can also tune the audio level on most stations.

Some call types include a 'volume override' function. These calls will ignore the station volume setting.

### **Capacity**

See *section 8 Specifications* for information on capacity for the different ACM systems.

## **3.1.3 Public Address and General Alarm**

The ACM system in conjunction with the SPA-V2 system provides PA and GA services according to marine requirements. The overall solution supports the following applications:

- PA for conventional vessels
- Integrated PA and GA
- PA for passenger vessels

The following marine regulatory requirements are supported.

- PA and GA coverage
- Redundant PA panels and priority between PA panels
- Protection from unintentional use
- Volume control and volume override
- PA and GA broadcast in noisy areas
- Muting of entertainment
- Interface to external GA systems
- Muting of GA during PA announcements
- Management of acoustic feedback
- Power redundancy
- Redundant PA and GA infrastructure

### **PA and GA coverage**

PA and GA coverage shall be provided in the areas as listed in table 1. The integrated speaker in the ACM intercom station shall provide PA and GA announcements together with the speakers connected to the SPA-V2 system.

### **Redundant PA panels and priority between PA panels**

Emergency PA announcements can be given by ACM intercom stations as well as SPA-V2 Public Address panels.

There are restrictions as to which ACM intercom panels are allowed to perform emergency PA announcements, normal PA announcements, or no PA announcements. This is set by the service profile (Class of Service) parameters in the ACM exchange for the individual intercom stations.

An ACM intercom station that is set up as an emergency PA panel will take the highest priority and override calls from other PA panels.

### **Protection from unintentional use**

In order to hinder and protect the stations from unintentional use, the user must carry out a two stage procedure to broadcast PA announcements.

### **Volume control and volume override**

At commissioning, the volume level for each ACM intercom level is adjusted via the AlphaPro programming tool.

Some of the ACM intercom stations have local volume control to adapt volume to the desired level. However, during a PA announcement the ACM intercom exchange will carry out a volume override of the volume level as set in AlphaPro.

### **PA and GA broadcast in noisy areas**

The ACM system has relay outputs that will drive flashing lights in noisy areas during a PA and GA announcement.

### **Muting of entertainment**

The ACM system will give a signal to the SPA-V2 system to mute music entertainment during PA and GA broadcasts.

### **Muting of GA during PA announcements**

The GA alarm is generated within the SPA-V2 system. During PA announcements, the SPA-V2 system will mute GA.

### **Interface to external GA systems**

External GA systems such as sirens and beacons are connected to the SPA-V2 system.

### **Management of acoustic feedback**

In some situations, there may be problems with acoustic feedback between PA panels and neighboring speakers. The ACM system manages acoustic feedback by using:

- Mutual exclusion
  - When configuring mutual exclusion between a set of neighboring intercom stations, these intercom stations will be muted during a PA announcement from one of the intercom stations in this mutual exclusion group.
- PA recall
  - PA recall allows the operator to first record an announcement into ACM. When the announcement is done, the operator can release

the announcement for broadcast to the speakers.

### **Power redundancy**

The ACM system is, by default, powered from an online UPS with battery backup and mains power. It is recommended to use the UPS as the primary power source.

As an option, the ACM system can be powered from the mains as the primary power source. The ship's 24 VDC power supply will then act as an emergency power source.

### **Redundant PA & GA infrastructure**

Passenger vessels and installations where PA and GA are integrated in one system have special requirements regarding redundancy.

- **Speaker loops**

All public areas shall be served with two independent speaker loops (A-loop and B-loop).

- The intercom stations connected to the ACM system will provide the A-loop.
- The SPA-V2 system will provide the B-loop as well as cover the remaining areas in the B-loop where there are no intercom stations.

- **Redundant rack equipment - conventional vessels**

An integrated PA and GA system requires redundant rack equipment.

- The figure shows how the rack equipment is duplicated by using one ACM system together with SPA-V2.

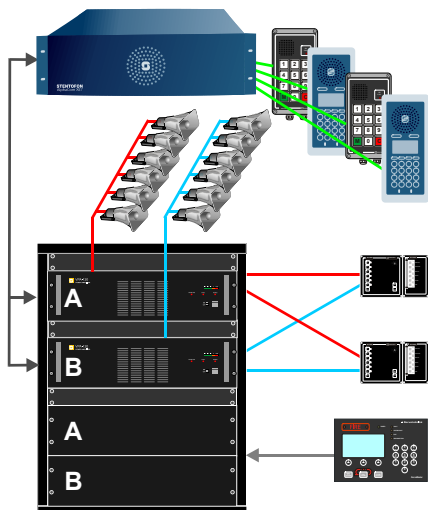

Figure 3 Basic PA & GA for conventional vessels

- **Redundant racks - passenger vessels**

Passenger vessels require two PA racks, each located in a different fire zone.

- The figure shows how the racks are duplicated by using an ACM system together with one SPA-V2 rack in one fire zone and a second SPA-V2 rack in another.

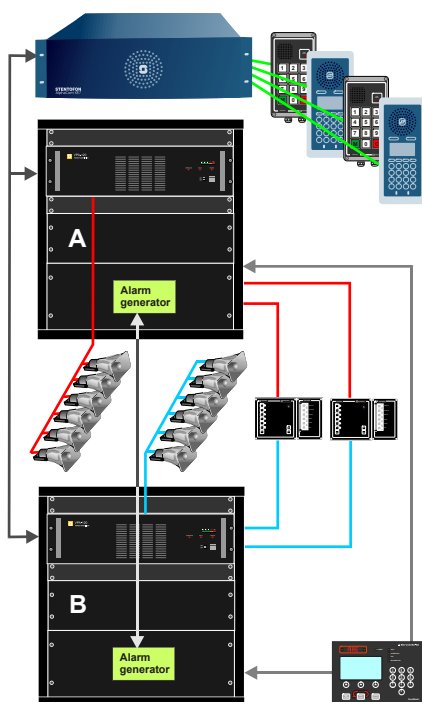

Figure 4 Basic PA & GA for passenger vessels

### 3.1.4 Handsfree two-way communication (Talk-Back)

Handsfree two-way communication is used to coordinate operation and activities in a group. It is important that the members in the group hear all conversations and have their hands free to work.

The ACM system enables handsfree two-way communication with the ACM simplex conference functions.

- When the bridge and UHF radios talk into a conference, they need to use the push-to-talk key.
- Other members only need to press the push-to-talk key to become an active talker.

#### **Bridge control stations**

The IP Flush Master Station with display is used as a bridge control station. To improve the operation of the bridge control station, a separate IP DAK-48 unit can be added. This unit provides visual indications on active participants (red LED) and active talker (green LED) as well as direct access keys to start a talk-back conference, add or remove participants, and switch to active talker.

#### **Other talk-back positions**

The VMP-530 and VMP-503 stations are used in the other talk-back positions. These stations can be extended with an external speaker for louder volume and/or headset.

For both VMP-530 and VMP-503, you need to press the push-to-talk key to become an active speaker in the conference. When the VMP station is the active talker in the conference, this will be indicated by the red LED on the VMP-station

#### **DECT handsets**

The ACM system supports cordless DECT handsets. These can be extended with industrial headsets.

It is possible to add DECT handsets to the talk-back conference. The user of DECT handsets need to push a key to become the active talker in the conference. When a DECT handset is the active talker in the conference, this will be indicated by the green LED for the DECT handset.

#### **UHF radio**

The ACM system supports integration with UHF radio. It is possible to add UHF radios into the talk-back conference.

Users of UHF radios need to press the push-to-talk key to talk into the conference. When an UHF radio is the active talker in the conference, this will be indicated by the green LED for the UHF radio.



Figure 5 DECT and UHF interface

# 4 Hardware Installation Instructions

## 4.1 General Environment Requirements

The ACM system has been tested and fulfills all requirements according to EN 60945 and IACS E10 standards.

**Rack Temperature:** -15°C to +55°C

**Humidity:** At 25°C <95% RH, at 55°C <93% RH

**Compass safety:** Distance ACM/SPA rack: 325 cm  
Distance ACM panels: 95 cm

- ① *We strongly recommend installing the rack in a ventilated technical instrument room with temperatures between 18 °C and 25 °C. This will extend the life span of the system.*

## 4.2 System Rack Mounting

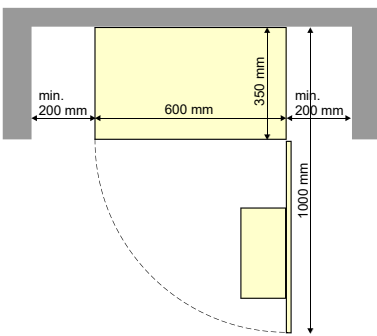

Figure 6 Clearance Dimensions for ACM-M-A & ACM-M-D cabinets

### 4.2.1 ACM-M-A-V2 / ACM-M-D-V2

The ACM-M-A-V2 and ACM-M-D system racks are made for wall mounting. Mount the cabinet at a convenient height, with the bottom about 1.2 m above the floor.

Cable inlet is at the bottom of the system rack.

Make sure there is enough space around the rack for connection and servicing.

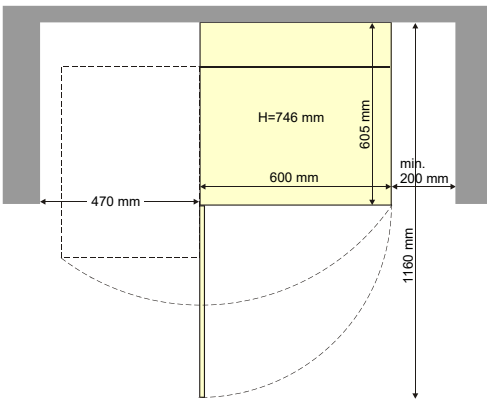

### 4.2.2 ACM-48-V10

The ACM-48-V10 system rack is made for wall or floor mounting. Mount the cabinet at a convenient height, with the bottom about 1.2 m above the floor.

Cable inlet is at the bottom of the system rack.

Make sure there is enough space around the rack for connection and servicing.

Figure 7 Clearance Dimensions for ACM-48-V10 cabinet

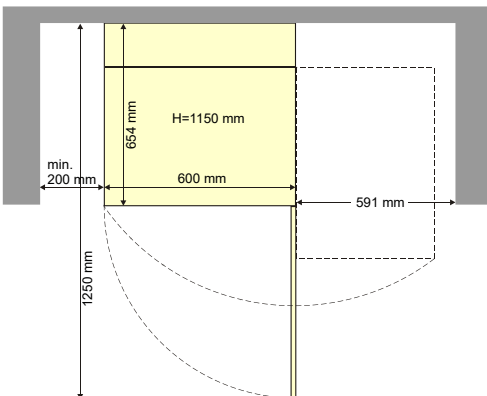

### 4.2.3 ACM-M-D/IP72 / ACM-M-D/IP96

The ACM-M-D/IP72 / ACM-M-D/IP96 system rack is made for floor mounting.

Cable inlet is at the bottom of the system rack.

Make sure there is enough space around the rack for connection and servicing.

Figure 8 Clearance Dimensions for ACM-M-D/IP72 & ACM-M-D/IP96 cabinets



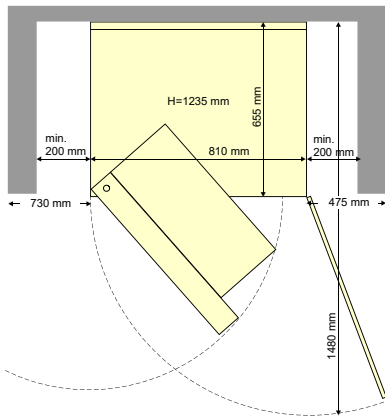

Figure 9 Clearance Dimensions for ACM-144-V10 cabinet

#### 4.2.4 ACM-144-V10 / AACM-144-V10

The ACM-144-V10 and AACM-144-V10 system racks are made for floor mounting.

Cable inlet is at the bottom of the system rack.

Make sure there is enough space around the rack for connection and servicing.

The AlphaCom exchange frame should be able to swing out 180° in order to access the connection field at the rear of the cabinet.

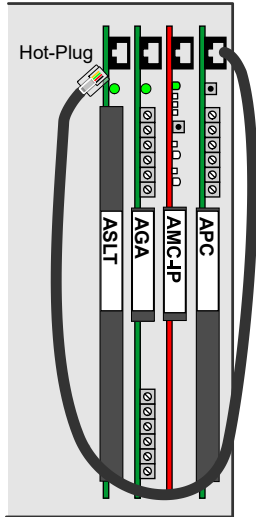

Figure 10 Hot-plug

### 4.3 Installing Feature Boards

Open the front cover of the AlphaCom XE exchange using a Philips screwdriver.

#### 4.3.1 Hot-plug

In AlphaCom XE20 and XE26 exchanges, all boards may be inserted or removed without switching off the power by inserting the powered RJ45 hot-plug from the APC board in the hot-plug receptor found at the top of all cards prior to removal or insertion.

- Remove the RJ45 hot-plug when the board is in place.

In an AlphaCom XE7 exchange, the power must be switched off prior to removal or insertion of boards as this exchange does not have the APC board or hot-plug feature.

**It is strongly recommended to wear a grounded wrist strap when handling electronic boards to avoid electrostatic discharges that may seriously damage the electronic circuits!**

#### 4.3.2 AMC-IP - AlphaCom Module Controller Board

All AlphaCom servers in the XE series have one AMC-IP board delivered at shipment.

This AMC-IP board is the next generation multi-service board developed for the STENTOFON AlphaCom XE series. The board is made for critical communication and security solutions featuring an embedded real-time Linux operating system, integrated media processing engine, packet processing engine, HW encryption, and storage module.

The AMC-IP board provides full backwards compatibility for both software and hardware. All traditional AlphaCom services and interfaces are supported. The board can support traditional AlphaCom feature boards and cabinets.

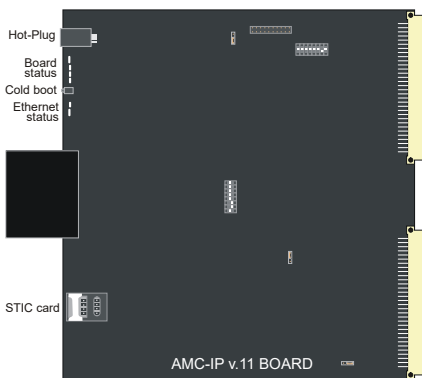

#### STIC

The STENTOFON Identity Card (STIC) is the logical identity of the AMC-IP board. The STIC contains the unique network identifier and network settings for the AMC-IP board, making it possible to replace the AMC-IP with just a simple restore operation.

The AMC-IP board comes with a SIM-sized card holder for the STIC. When delivered, the STIC resides within a card that is the size of a regular credit card. Detach the smaller STIC by gently pressing it out. Keep the remaining part of the card as the MAC address programmed in the STIC is printed on it.

There are different STICs for XE1/XE7 and XE20/XE26 servers.



### 4.3.3 Board positions

The AMC-IP and APC boards are always mounted in fixed positions. Line boards are mounted according to customer requirements: ASLT boards for 6 x 4-wire intercom stations and ATLB-12 boards for 12 x telephone lines. These boards are inserted from the lowest number positions upwards.

When RCO relay contacts are required, ASLT board(s) must be mounted in dedicated positions.

If the RCI and audio inputs from the APC board are used, they will substitute the last line board on the last LCM module.

BOARDS			BOARD POSITIONS		
Type	Board Name	Part Number	XE7	XE20	XE26
APC	Program and Clock	100 9301 000	-	26	26
AMC-IP	AlphaCom Module Controller	100 9202 100	7	25	25
ASLT	6 Subscriber Lines	100 9101 010	1-6	1, 8-23	1-19
	6 RCO relay contacts used	100 9101 010	2	8, 14	2, 8, 14, 20
ATLB-12	12 Telephone Lines	100 9104 000	1-6	1, 8-23	1-19

Table 2 Board Positions

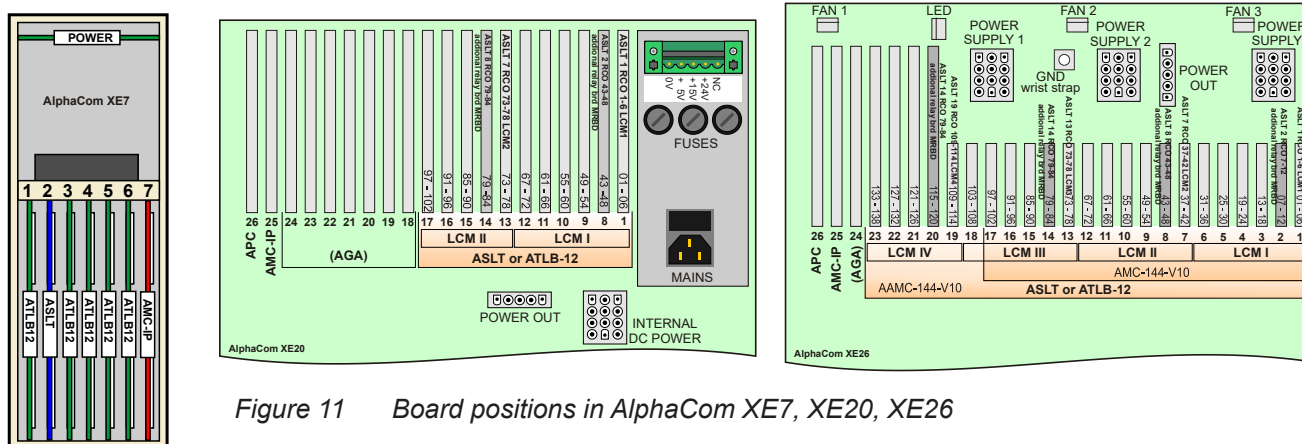

Figure 11 Board positions in AlphaCom XE7, XE20, XE26

## 4.4 Connection Terminals

The ACM-M system is shipped with an ACM Programming and Cable Reference list. This list shows how the external wiring shall be connected to the different terminal blocks. See *Section 5* for example.

### 4.4.1 ACM-M-A-V2 and ACM-M-D

Connectors and terminals for power and external equipment are accessible at the rear of the ACM-M-A-V2 and ACM-M-D cabinet. To access the connectors, open the cabinet door and swing out the AlphaCom XE7 exchange.

Cable inlets are at the bottom of the cabinet and there is a cable fastening bar in the lower part. All internal cabling is ready-made from the factory and routed in cable conducts.

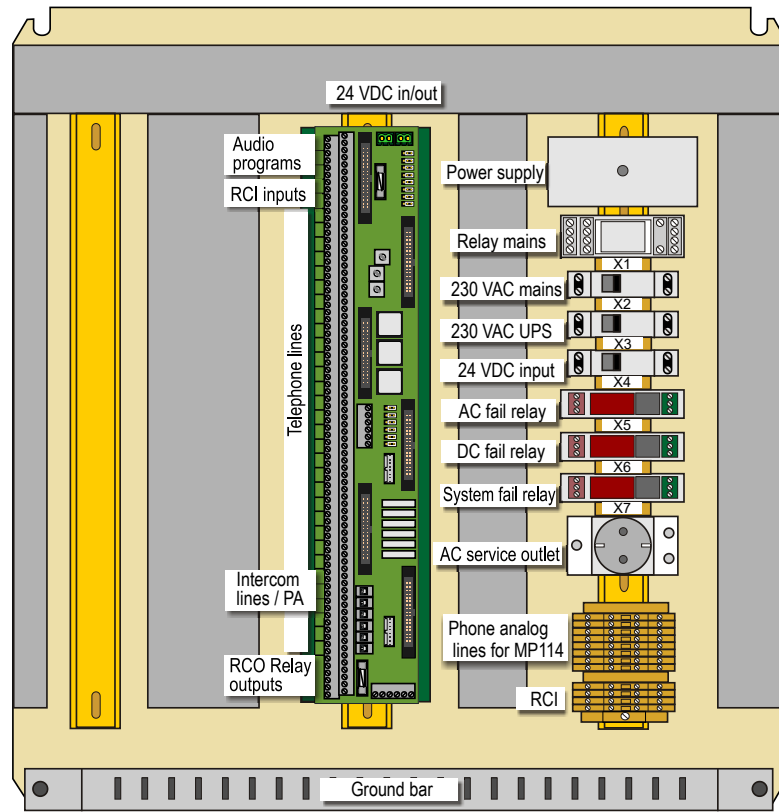

Figure 12 Terminals in ACM-M-A-V2

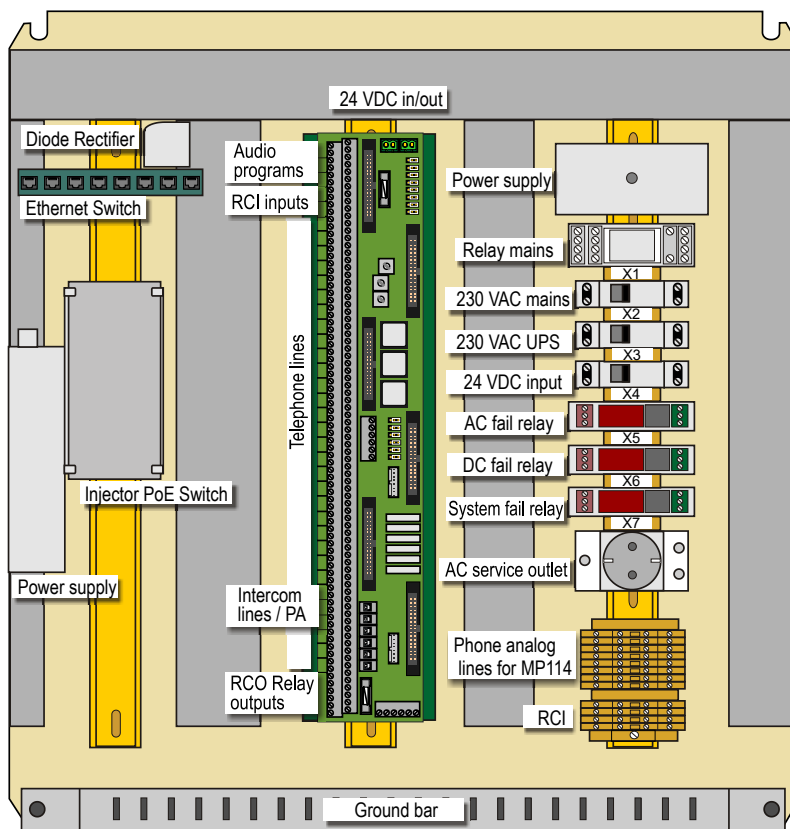
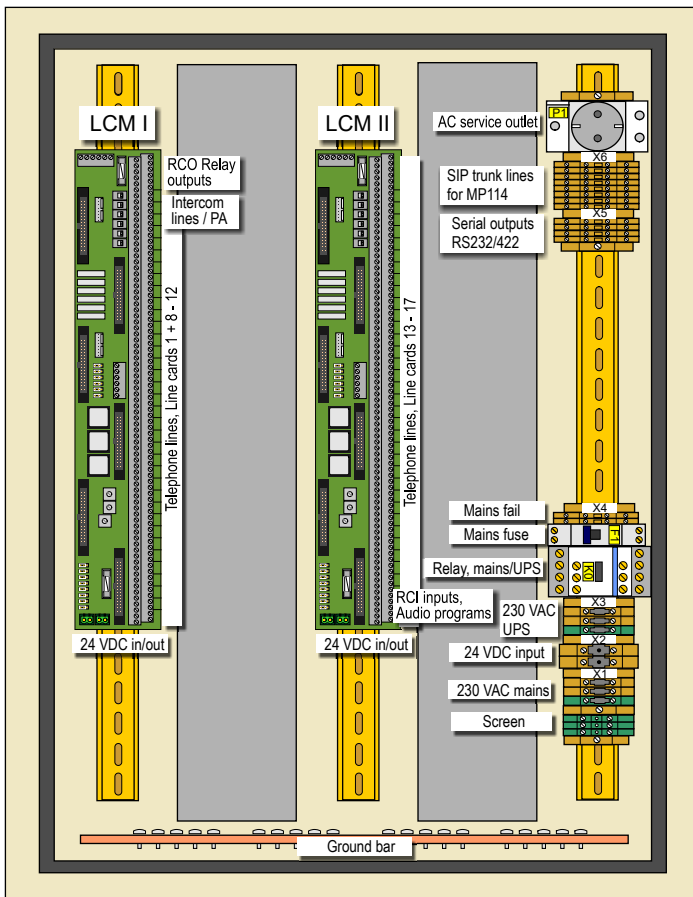

Figure 13 Terminals in ACM-M-D

#### 4.4.2 ACM-48-V10



Connectors and terminals for power and external equipment are accessible inside the door of the ACM-48-V10 cabinet. To access the connectors, open the cabinet door.

Cable inlets are at the bottom of the cabinet and there is a cable fastening bar in the lower part. All internal cabling is ready-made from the factory and routed in cable conducts.

The number of terminals and physical placement of terminals for power, etc. may vary according to optional equipment and installation requirements. See the documentation for the actual project for exact layout and connections.

Figure 14 Terminals in ACM-48-V10

#### 4.4.3 ACM-144-V10 and AACM-144-V10

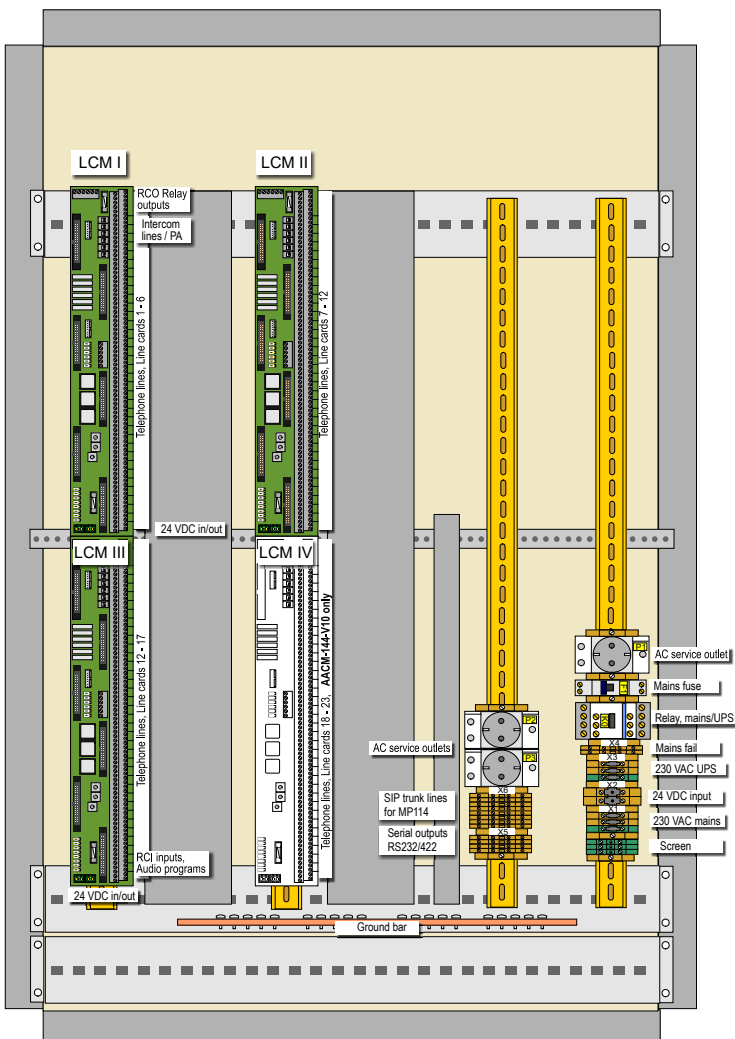

Connectors and terminals for power and external equipment are accessible at the rear of the ACM-144-V10 and AACM-144-V10 cabinets. To access the connectors, open the cabinet door and swing out the AlphaCom exchange frame.

Cable inlets are at the bottom of the cabinet and there is a cable fastening bar in the lower part. All internal cabling is ready-made from the factory and routed in cable conducts.

ACM-144-V10 has 3 LCM terminal modules, while AACM-144 has 4.

The number of terminals and physical placement of terminals for power, etc. may vary according to optional equipment and installation requirements. See the documentation for the actual project for exact layout and connections.

Figure 15 Terminals in ACM-144-V10 & AACM-144-V10

#### 4.4.4 ACM-M-D/IP72 / ACM-M-D/IP96

Connectors and terminals for power and external equipment are accessible at the rear of the ACM-M-D/IP72 and ACM-M-D/IP96 cabinets. To access the connectors, open the cabinet door and swing out the AlphaCom exchange frame.

Cable inlets are at the bottom of the cabinet and there is a cable fastening bar in the lower part. All internal cabling is ready-made from the factory and routed in cable conducts.

The number of terminals and physical placement of terminals for power, etc. may vary according to optional equipment and installation requirements. See the documentation for the actual project for exact layout and connections.

### 4.5 Power Supply

See also *Appendix C – Internal Wiring in System Racks*.

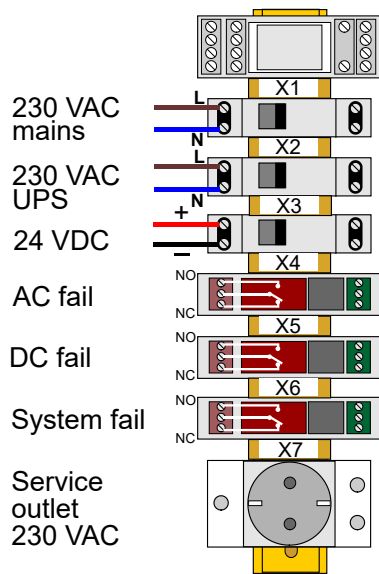

Figure 16 ACM-M-A/D Power connection

#### 4.5.1 ACM-M-A-V2 / ACM-M-D

- The ACM-M-A-V2 and ACM-M-D are powered from 230 VAC mains with automatic switch-over to 230 VAC UPS or 24 VDC emergency power.
- All internal power cabling is ready-made from the factory and routed in cable conducts.
- Connect 230 VAC mains to L and N terminals on the X1 circuit breaker
- Connect mains earth to the ground bar
- Connect 230 VAC UPS power to L and N terminals on the X2 circuit breaker if this backup power is used
- Connect 24 VDC emergency power to the + and - terminals on the X3 circuit breaker if this backup power is used
- The 230 VAC mains outlet X7 is used for service purposes.

#### Power failure

Three power fail relays are included to indicate the types of failures. Each relay has a NO/NC switch-over contact to indicate 'Power good/fail'. The relays are activated when the actual power is OK, which means that the NO contact is closed and NC is open under normal conditions.

- X4 is released if the 230 VAC power fails (mains and UPS)
- X5 is released if the 24 VDC emergency power fails
- X6 is released if the 24 VDC output power from AMC-XE7 fails

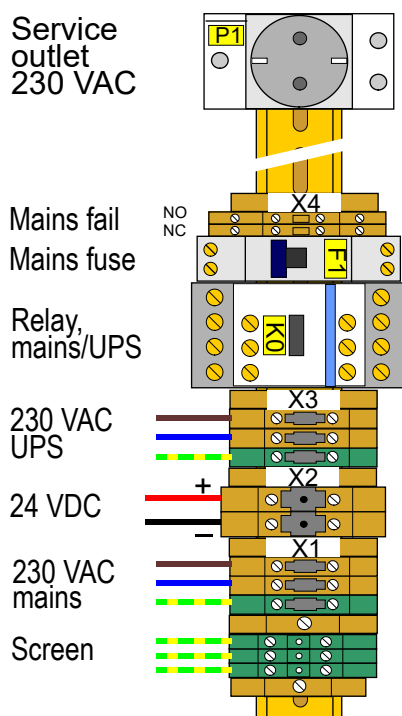

#### 4.5.2 ACM-48-V10 / ACM-144-V10 / AACM-144-V10

- The ACM-48-V10, ACM-144-V10 and AACM-144-V10 are powered from 230 VAC mains with automatic switch-over to 230 VAC UPS.
- As an option, it is possible to deliver the system racks with automatic switch-over to 24 VDC emergency power.
- All internal power cabling is ready-made from the factory and routed in cable conducts.
- Connect the 230 VAC mains to L and N terminals on the X1 connector
- Connect the UPS power to L and N terminals on the X2 circuit breaker if this backup power is used
- Connect 24 VDC emergency power to the + and - terminals on the X3 circuit breaker if this backup power is used
- The 230 VAC mains outlets P1, P2 and P3 are used for service

purposes.

- The 10 A mains fuse F1 is connected after the UPS relay K0.

#### **Power failure**

- Relay P0 is engaged as long as the mains power is present. If the mains power fails, the 230 VAC UPS or optional 24 VDC will be connected. A set of NO/NC contacts are available at X4 terminal for indication and warning.

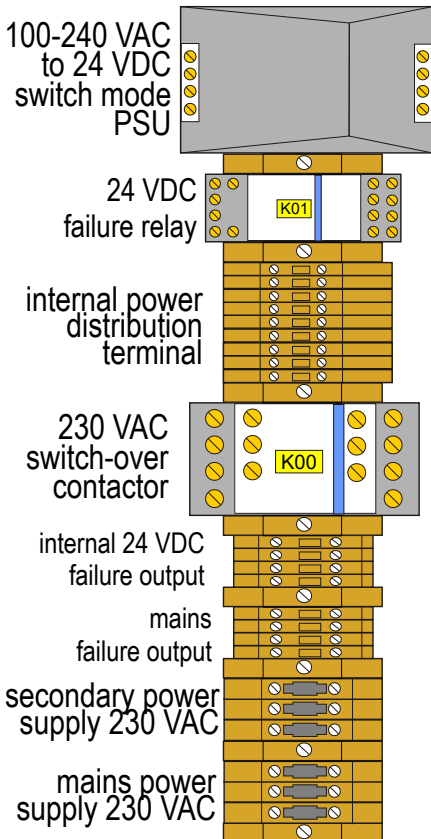

#### **4.5.3 ACM-M-D/IP72 / ACM-M-D/IP96**

- The ACM-M-D/IP72 and ACM-M-D/IP96 are powered from 230 VAC mains with automatic switch-over to 230 VAC UPS.
  - As an option, it is possible to deliver the system racks with automatic switch-over to 24 VDC emergency power.
- All internal power cabling is ready-made from the factory and routed in cable conducts.
- Connect the 230 VAC mains to L and N terminals on the X1 connector
- Connect the UPS power to L and N terminals on the X2 circuit breaker if this backup power is used
- Connect 24 VDC emergency power to the + and - terminals on the X3 circuit breaker if this backup power is used
- The 230 VAC mains outlets P1, P2 and P3 are used for service purposes.
- The 10 A mains fuse F1 is connected after the UPS relay K0.

#### **Power failure**

- Relay P0 is engaged as long as the mains power is present. If the mains power fails, the 230 VAC UPS or optional 24 VDC will be connected. A set of NO/NC contacts are available at X4 terminal for indication and warning.

Figure 17 ACM-M-D/IP72 / ACM-M-D/IP96 Power connection

#### **4.5.4 Cable dimensions**

All mains and UPS cables should be 1.5 mm<sup>2</sup>.

If 24 VDC should be used as emergency power, the power source capacity as well as the cable length and cross-section must be evaluated. Keep in mind that the minimum voltage at the ACM terminal should not be lower than 20 V.

- Make sure that the 24 VDC source is capable of delivering the required current. The power and current values in the table below are for a fully equipped exchange in all-call and all stations at maximum volume.
- The cable resistance must not exceed the values listed below to avoid too high a voltage drop (2 V per cable).
- Calculate the required cable cross-section from a cable resistance/ meter table. The values in the table below are for guidance only.

Exchange type	Max. 230 V inlet power	Max. current on 24 V inlet	Max. 24 V cable resistance	Cable (mm <sup>2</sup> )	
				230 VAC	24 VDC
ACM-M-A-V2/D	260 W	11 A	0.180 Ω	1.5	2.5
ACM-48-V10	450 W	23 A	0.087 Ω	1.5	6

ACM-144-V10	510 W	25 A	0.080 Ω	1.5	6
AACM-144-V10	580 W	30 A	0.067 Ω	1.5	8

Table 3 Power and cable values

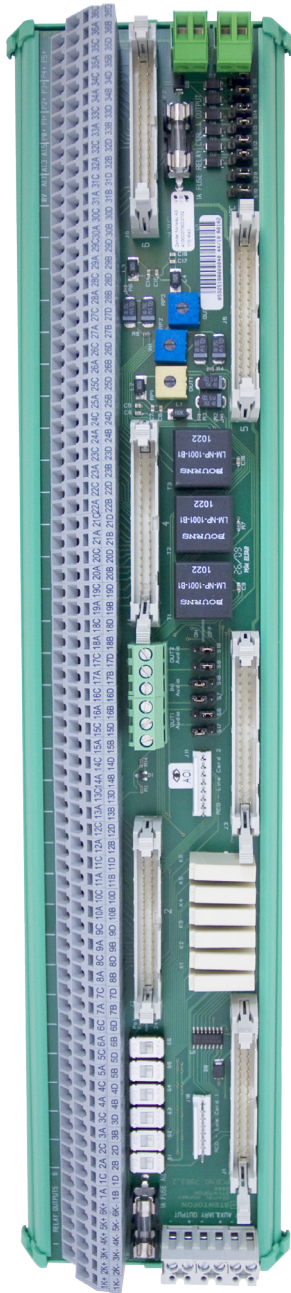

## 4.6 Line Connection Module (LCM)

All line connections for analog intercom and phones are made to the Line Connection Module board. This board substitutes the former 6 x Line Termination boards.

This module also substitutes the Power Distribution board, VA-502 Relay Unit board with 6 RCO relays and VA-503 Filter and Speech Adapter board with 2 audio outputs, 1 audio input and PTT relay if these functions are used.

The module has connectors for:

- **24 VDC Power**
  - Input
  - Output
  - 3 x 1 A fused outputs
  - 6 x relay controlled switch selected RCO outputs, 1 A common fuse
- **Line points**
  - Max. 36 x analog intercom stations on 6 x ASLT boards or
  - Max. 60 x analog telephone lines on 5 x ATLB12 boards
    - + max. 5 x 4-wire intercom stations on 1 x ASLT board
    - + 1 x intercom station as PA monitor
- **RCO**
  - 1 x relay contact for PA control
  - 5 x relay contacts, potential-free or +24 V (switch selection)
- **RCI**
  - (Needs APC board, not used in ACM-M-A-V2)
  - 6 x closing contact inputs referred to 0 V
- **PA/GA or radio input**
  - (Needs APC board, not used in ACM-M-A-V2)
  - 6 x potential-free 600 ohm, 0 dB lines
- **Radio/Walkie-talkie interface**
  - (Needs APC board, not used in ACM-M-A-V2)
  - Potential-free adjustable audio in and out
  - RCO relay can be used for PTT control
- **PA audio output**
  - Audio output for PA with possibility for monitoring intercom stations in parallel

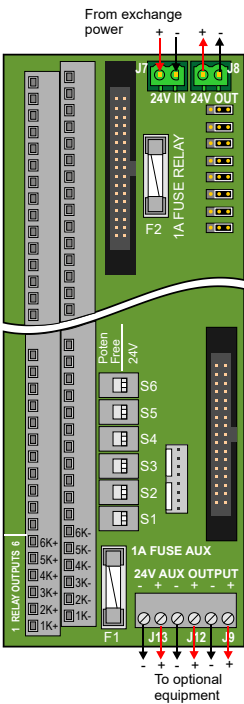

Figure 18 24 VDC connections

### 4.6.1 24 VDC power

The electronic circuits on the LCM board is powered by 24 VDC from the exchange. The power is connected to terminal J7.

- Use 2.5 mm<sup>2</sup> cables.

24 VDC is available on one unfused terminal (J8) as well as three terminals (J9, J12 and J13) fused by 1A (F1). These are used for distributing 24 VDC to other equipment.

The six RCO relays may deliver 24 VDC on terminals 1K-6K if selected by on-board switches S1 to S6. The relay control and output power is fused by 1A (F2).

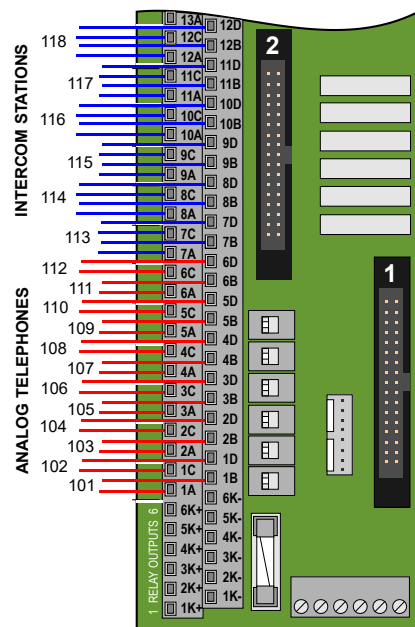

Figure 19 Telephone and intercom line connection example

### 4.6.2 Subscriber lines

The line board terminals are available at the AlphaCom XE backplane. The line points are routed to the LCM through 17-pair flat cables. The subscriber lines are connected to corresponding terminals on the Line Connection Module board.

All interconnection cables are ready-connected according to project at delivery. See the technical manual *A100K10610 Line Connection Module* for further information.

All LCM terminals are marked, starting at 1A, 1B, 1C and 1D. The analog intercom uses 4 wires and will use A, B, C and D positions. The analog telephone line use two wires, where one line is connected to A/B and a second line is connected to C/D.

The ACM systems are shipped with an ACM Programming and Cable Reference list. This list shows where to connect the subscriber lines. See *Section 5* for example.

The subscriber line cable must be an approved ship cable type with 0.75 mm<sup>2</sup> twisted pairs and an outer braided tinned copper screen. The screen must be interconnected in junction boxes and grounded to a common ground point in the ACM system rack only.

### 4.6.3 RCO - Remote Control Outputs

There are outputs from 6 RCO relays which can be programmed to operate external features like extra signal devices in noisy areas.

All RCO functions are programmed in AlphaPro. The RCO 1-6 signals are taken from the first line board on each LCM. It is possible to use six additional RCOs on each LCM by connecting an MRBD relay board.

The outputs are individually selected to be a potential-free relay dry contact or +24 V. The selection is made by the switches S1 – S6. S1 is related to RCO 1 and so on.

The devices are connected to the RELAY OUTPUT terminals marked 1K+/1K- to 6K+/6K-.

RCO 1 on 1K is reserved for PA activation. Switch S1 must be in *Pot. free* position.

The relay contacts are rated to maximum 5 A / 30 VDC or 250 VAC resistive load. The internal +24 V is protected by a 1 A slow fuse F2





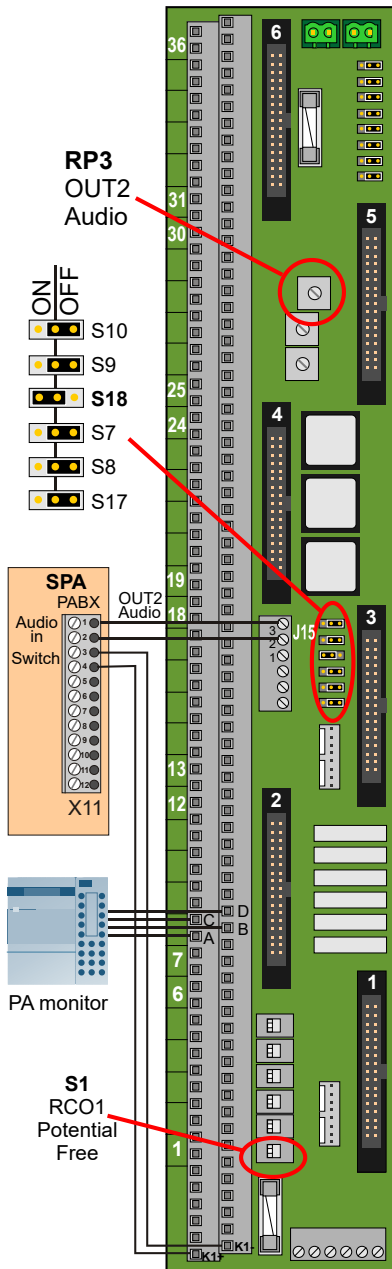

SPA-V2 does not have any dedicated input for ACM/AlphaCom audio. Several solutions are possible while two alternatives are normally used.

**Alternative 1** – connect to X11, **PABX** (or X12, **PABX with recall** if X11 is already used).

- Used when ACM shall have lower priority than microphones.
- Preferred solution for analog ACM exchanges with one-way audio announcements (ACM-M-A-V2).

**Alternative 2** – connect to X7, **Talk-Back**.

- Normally not suited for ACM-M-A-V2 unless ACM must have highest priority.
- Preferred solution for digital ACM exchanges with two-way audio.

#### 4.6.6 PA amplifier with chime, without monitor

- Connect a screened, twisted pair cable between pins 2/3 on terminal J15, **OUT2 Audio** on the LCM unit and pins 1/2 on terminal X11, (X12) on the SPA-TERM board which is connected to the CALL input in the PA amplifier. Connect the cable screen to system ground.
- Connect cables between terminals 1K+/1K- on the LCM unit and pin 3/4 on terminal X11 (X12) on the SPA-TERM board which is connected to the PRIORITY terminal in the PA amplifier.
  - This will establish a chime signal in front of a call. The CHIME switch in the PA amplifier must be **ON**.
- Set switch S18 to **ON** to activate the audio filter
- Set switch S9 to **ON** to simulate audio-out load when monitor station is missing
- Set switch S10 to **ON** to simulate audio-in load when monitor station is missing
- Leave switches S7, S8 and S17 **OFF**.
- Set volume control RP3, **OUT2**, to mid position.
  - This must be readjusted to  $1 \pm 0.5$  Vrms during live test
- Set switch S1 in **Potent. Free** position for chime activation.

#### Intercom station as PA monitor

- Connect the PA amplifier and chime relay as described above.
- Connect an intercom station to line point 8A/B/C/D
- Set switch S18 to **ON** to activate the audio filter
- Leave all other switches **OFF**

PA on OUT2 Audio	STATION	CONNECT TO	S9	S10	S18
NO	Normal	8A/B/C/D	NA	OFF	OFF
YES	NO	-	ON	ON	ON
YES	PA Monitor	8A/B/C/D	OFF	OFF	ON

Table 4 Switch settings for PA monitoring

See the *ACM-M-A-V2 manual A100K10430* for PA programming.

#### Zone selection

ACM-M-A-V2 use one common zone only. This 'All-call' is initiated by dialling 84.

In maritime environments, Public Address is normally divided into 4 zones. Each zone can be selected by dialling 85, 86, 87 or 88. Only one zone can be selected for each announcement.

Four RCO relay outputs are used to select the zones:

- Zone 1      RCO2 terminal 2K+/-
- Zone 2      RCO3 terminal 3K+/-
- Zone 3      RCO4 terminal 4K+/-
- Zone 4      RCO5 terminal 5K+/-

- Set switches S2, S3, S4 and S5 to **Pot. free**

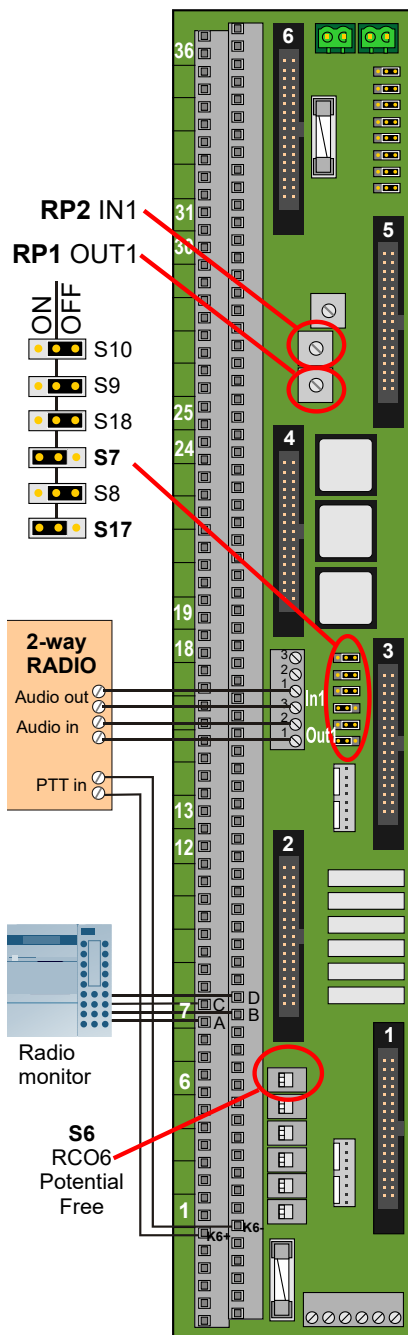

#### 4.6.7 Radio / Walkie-talkie Interface

A two-way radio or Walkie-talkie can be connected as part of the intercom system.

The first intercom subscriber line on line board 2 (physical no. 7 in ACM XE7 and XE26 or physical no. 43 in ACM XE20) is used as audio interface to the radio. The audio in and out from this line can be routed through filters and volume controls to connector J14/1-2 (**IN1 Audio** and J14/3-J15/1, **OUT1 Audio** by setting jumpers S7 and S17 to ON.

The RCO-6 output may be used as a PTT control.

It is possible to connect an intercom station to the same line (line connection point 7ABCD on the terminal strip) for use as a radio conversation monitor.

**Do NOT connect an amplifier to line point 8A/B as the 40 kHz signal carrier may seriously damage the equipment!**

The Radio or Walkie-talkie is reached by dialling its directory number, default:

- ACM-M-A-V2:      113
- ACM-48-V10:     143
- ACM-144-V10:    107

- Connect a screened, twisted pair cable between pins 1/2 on terminal J14, **OUT1 Audio** on the LCM unit and the radio input terminal. Connect the cable screen to system ground.
- Connect a screened, twisted pair cable between pin 3 on terminal J14/ pin1 on terminal J15, **OUT1 Audio** on the LCM unit and the radio input terminal. Connect the cable screen to system ground.
- Connect cables between terminals 6K+/6K- on the LCM unit and the PTT terminal on the radio.
- Set switch S7 to ON to activate the audio input filter
- Set switch S17 to ON to activate the audio output filter
- Set switch S8 to ON to simulate audio-out load when monitor station is missing
- Set volume control RP1, **IN1**, to mid position.
  - This must be readjusted during live test
- Set volume control RP2, **OUT1**, to mid position.
  - This must be readjusted to 1±0.5 Vrms during live test
- Set switch S1 in **Pot. Free** position for PTT activation.

#### Intercom station as radio monitor

- Connect the radio audio and PTT relay as described above.
- Connect an intercom station to line point 7A/B/C/D
- Set switch S7 and S17 to ON to activate the audio filters
- Set switch S8 to OFF to remove the line load

RADIO Audio	STATION	CONNECT TO	S8	S7	S17
NO	Normal	7A/B/C/D	OFF	OFF	OFF
IN	NO	-	ON	ON	OFF
OUT	NO	-	ON	ON	ON

IN + OUT	NO	-	ON	ON	ON
IN	Monitor	7A/B/C/D	OFF	ON	OFF
OUT	Monitor	7A/B/C/D	OFF	OFF	ON
IN + OUT	Monitor	7A/B/C/D	OFF	ON	ON

Table 5 Switch settings for radio monitoring

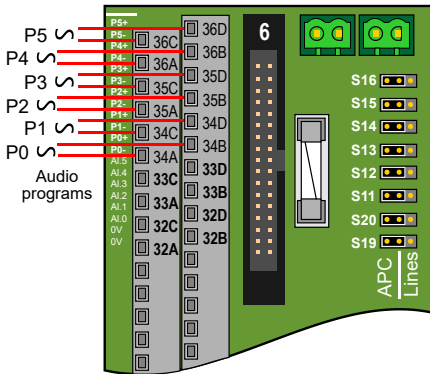

Figure 22 Audio input connection

#### 4.6.8 Audio input - 6 channels

This option requires the use of the APC - Program & Clock board. The option is not available in ACM-M-A-V2.

Using the Audio input option will reduce the line capacity on the last LCM module by one line board.

- An interface cable is connected between the APC filter board (card position 26) and the last line board connector (J6) on the last LCM module.
- Set all 8 jumpers S11-16 + S19-20 to the **APC** position.
- Connect the audio source cables to spring lock terminals P0+/- to P5+/- (34C - 36D). Use 2-wire screened cables to connect the screen to system ground.
- Each audio source volume level is individually adjusted on the APC board.
- The feature programming is done in AlphaPro.

### 4.7 ACM-IP Patch Panel & I/Os

The ACM-IP system comes with Bergen cabling CAT-6A patch panels preinstalled. These support Bergen cabling CAT-6A sockets. CAT-6A supports bandwidth up to 10 Gbps, and has the same speed as CAT-7.

## 5 Programming & Cable Reference List

The ACM programming and cable reference list consists of a set of tables summarizing the main information needed to program an ACM exchange for a vessel.

The standard programming is documented in a Microsoft Excel Spreadsheet. This sheet should be modified by the customer in accordance with his needs. This information is then used by the supplier to carry out the programming of the ACM exchange.

The exchange is delivered ready-programmed, but may be modified by the customer later on using the AlphaPro and AlphaWeb programming tools.

### 5.1 Station and User Information

STATION AND USER INFORMATION															
Dir. No.	Phys No.	Programming			Display text (Max 12 characters)	Station type:	Terminal connections						Information	Ext. field equipment	Board Pos.
		Group membership	Group Access Level	COS Priority			LCM	A	B	C	D	RCO			
101	1	1	2	5	Wheelhouse	TC1020	1	1	1				1K+, 1K-	Member ringing group 6701	1
102	2	1	2	5	Wheelhouse	TC1020	1			1	1		2K+, 2K-	Member ringing group 6701	1
103	3	1	0	1	Station 3	-	1	2	2				3K+, 3K-		1
104	4	1	0	1	Station 4	-	1			2	2		4K+, 4K-		1
105	5	1	2	4	Captain Day	TC1020	1	3	3				5K+, 5K-	Parallel ringing 1	1
106	6	1	2	4	Captain Bed	DT-800M	1			3	3		6K+, 6K-	Parallel ringing 1	1
107	277	1	2	3	Chief Eng. Day	HSB03	1	4	4					Parallel ringing 2	1
108	278	1	2	3	Chief Eng. Bed	DT-800M	1			4	4			Parallel ringing 2	1
109	279	1	0	1	Mess room	TC1020	1	5	5					Member ringing group 6701	1
110	280	1	0	1	Hospital	DT-800M	1			5	5				1
111	281	1	0	1	Station 11	-	1	6	6						1
112	282	1	0	1	Station 12	-	1			6	6				1
113	7	1	0	1	Station 13	-	1	7	7	7	7			Intercom station	2
114	8	1	0	1	PA monitor	VMP-619	1	8	8	8	8			PA monitor station	2
115	9	1	0	1	Station 15	-	1	9	9	9	9			Intercom station	2
116	10	1	0	1	Station 16	-	1	10	10	10	10			Intercom station	2
117	11	1	0	1	Station 17	-	1	11	11	11	11			Intercom station	2
118	12	1	0	1	Station 18	-	1	12	12	12	12			Intercom station	2
119	13	1	0	1	Station 19	-	1	13	13						3
120	14	1	0	1	Station 20	-	1			13	13				3
121	15	1	0	1	Station 21	-	1	14	14						3
122	16	1	0	1	Station 22	-	1			14	14				3
123	17	1	0	1	Station 23	-	1	15	15						3
124	18	1	0	1	Station 24	-	1			15	15				3
125	289	1	0	1	Station 25	-	1	16	16						3
126	290	1	0	1	Station 26	-	1			16	16				3

Table 6 Station and user information example

#### 5.1.1 Station information

- **Directory Number**
  - The number to dial to reach the station.

By default, successive 3-digit numbers from 101 to 166 are set.
- **Physical Number**
  - All stations are identified by the exchange with its physical number.
  - The first 6 lines on the ATLB12 card are numbered 1, 2, 3 and so on up to 36, while the last 6 lines are numbered 277 to 312.
  - See *section 4.6.1* for a list of physical numbers.
- **Display Text**
  - The station ID text shown in the called station's display.
  - Even if the telephones or intercom stations do not have a display,

this text must be entered as the info is used for other forms of identification like logging, billing and DECT display.

The default text should normally be substituted by the station location or the subscriber's name. The maximum number of characters is 16 including the station directory number.

- **Station Type**

- Used to define the type of station, e.g. *DT-800M* or *TC1020D*

## 5.1.2 Programming

- **Group membership**

- A station may be a member of several groups.

By default, all stations are members of Group 1. Group 1 defines all stations that shall receive emergency PA announcements.

① *Analog telephones will receive the PA announcement only if they are in a conversation.*

- **Group Access Level**

- Used to specify which group and PA calls a user may perform.

Each group used for group and PA calls will have an associated **Group Access Level**. The levels are:

*Low (=0), Medium(=1) and High(=2).*

The user must have a higher or the same group access level.

By default, the group used for emergency PA announcement is programmed as *group 1* with group access level *high*. Only users with group access level *high* can make an emergency PA announcement.

- **Class of Service (COS)**

- COS determines which system features the station can activate.

There are 16 different classes available and each can be freely programmed. A station (analog telephone) can only have one defined COS.

An ACM solution is usually programmed with the following available Class of Service:

- COS 1 Regular stations in the system
- COS 2 Notify busy station
- COS 3 Override of absent or private feature
- COS 4 Busy override
- COS 5 Override of busy, absent and private
- COS 16 Includes all services. Default for Super User

## 5.1.3 Terminal connections

- **LCM**

- The LCM module number

ACM-M-A-V2 has only one module. Large exchanges (ACM-48, ACM-144) may have more than 60 subscribers and need two to four modules.

- **Station terminal number**

The A, B, C and D wires are the 4 wires used for stations.

- An intercom station uses all 4 wires.
- Analog telephones use 2 wires, either the A/B or C/D wires.

- **RCO**

- These are programmable relay outputs linked to the associated ACM physical numbers. (The first 6 on line board 1).

The RCOs are used to signal to external PA system and signal units.

## 5.1.4 Additions

- **Information**

Each station may have the following additional functions:

- **Members of a ringing group.** A ringing group is a group of stations that will receive external calls in parallel. Calls to a ringing group will have a distinct ringing tone.
- **Parallel ringing.** Stations that are set up belonging to the same parallel ringing will ring in parallel. Up to 10 stations can be in parallel ringing.

- **Ext field equipment**

- Field equipment are unit types that are installed in parallel on the line to the telephone set, for instance an IRR-3 relay box.

- **Board pos.**

- Line board position in the AlphaCom exchange.

## 5.2 Integrated PA Interface

By default, the system is programmed to support emergency PA announcements (ALL CALL) initiated from analog telephones with group access level = 2.

INTEGRATED PA INTERFACE									
Signal direction	Type	LCM	A	B	C	D	RCO	Terminal	Info
ACM to SPA	Audio 0dB	1	8	8				LCM, J15, OUT2 Audio	8A/B for PA monitor
ACM to SPA	PA - ALL CALL						RCO1	LCM, 1K+,1K-	S1 = Pot. free

Table 7 Integrated PA interface example

PA ALL CALL is accessed by directory no. 84. The call is configured with group access level 2 (high). Only subscribers with access level 2 can make PA ALL CALL.

- **Signal direction**

- The system initiating the PA call.

- **Type**

Type of signal on the interface. The different types are:

- Audio
- Normal call to a zone
- Emergency call to all stations and speakers
- Digital I/O
- Mute relay  
(used to signal 'mute' to external systems such as sirens).

- **RCO**

- Indicates the station associated with the remote control output.

- **Terminal**

- Specifies the ACM terminal block where the signal is connected.

## 5.3 IP Configuration

This table shows the IP configuration for the different components in the ACM rack if applicable.

IP CONFIGURATION				
Equipment	Port #	Note	IP address	Mask
ACM	Eth0	Master node	169.254.1.5	255.255.255.0
ACM	Eth1	Master node	10.1.0.10	255.255.255.0
Data switch	-		10.1.0.50	255.255.255.0
Telephone gateway, MP-11X	-		10.1.0.101	255.255.255.0
Alarm module	-		10.1.0.200	255.255.255.0
DECT Server	-		10.1.0.201	255.255.255.0
DECT BS-1	-		10.1.0.202	255.255.255.0
DECT BS-2	-		10.1.0.203	255.255.255.0
DECT BS-3	-		10.1.0.204	255.255.255.0
DECT BS-x	-		10.1.0.204	255.255.255.0

Table 8 IP Configuration example

## 5.4 Trunk Lines

TRUNK LINES:											
Dir. No.	SIP type		Node	Line	Incoming	Display text	FXO Terminal block				Additional functions
							A	B			
001	FXO	MP-114	2	1	6701	Trunk 1 Basic	1	2			
002	FXO	MP-114	2	2	6701	Trunk 2 Basic	3	4			
003	FXO	MP-114	2	3	101	Trunk 3 Extra	5	6			
004	FXO	MP-114	2	4	101	Trunk 4 Extra	7	8			

Table 9 Trunk lines example

- **Directory No.**
  - The number to dial to get an external trunk line.
- **SIP type**
  - The SIP gateway used for the trunk. Possible types are MP-114 and MP-118.
  - FXO is the supported analog telephone interface from the MP gateways.
- **Node**
  - The AlphaNet node number used for the SIP gateway. The default is 2.
- **Line**
  - The line number for the trunk.
- **Incoming**
  - The extension that the incoming calls on the trunk is placed to.
- **Display text**
  - The display text that is shown in the ACM station for incoming calls on the trunk.
- **Terminal block X6**
  - The physical position used for the trunk on the terminal block.
- **Additional functions**
  - Additional information on whether incoming calls shall be placed in parallel or sequential order if multiple stations shall receive the incoming call. If calls shall be placed in parallel to stations, these calls must be members of the same ringing group.



# 6 Programming Overview

The ACM exchanges are delivered ready-programmed, but may be modified by the customer after delivery.

The main tools used to program and manage ACM/AlphaCom are AlphaPro and AlphaWeb

## AlphaPro

AlphaPro is the professional tool for configuration of the ACM system. It is self contained, and simple to install and use. When a new exchange is to be configured, the exchange is given a default working factory setting suited for ACM. The operator can then modify the settings later. AlphaPro is an offline tool, meaning that all parameters can be entered without being connected to the exchange. Once all parameters are entered, AlphaPro can be connected to the exchange and the parameters can then be transferred. AlphaPro can also upload configuration information from an exchange. AlphaPro connects to the AlphaCom XE over an IP network.

## AlphaWeb

AlphaWeb is an embedded web server running on the AlphaCom XE server/exchange. It allows the users to log in using a standard web browser to operate and manage the AlphaCom system.

### 6.1 AlphaWeb - Getting Started

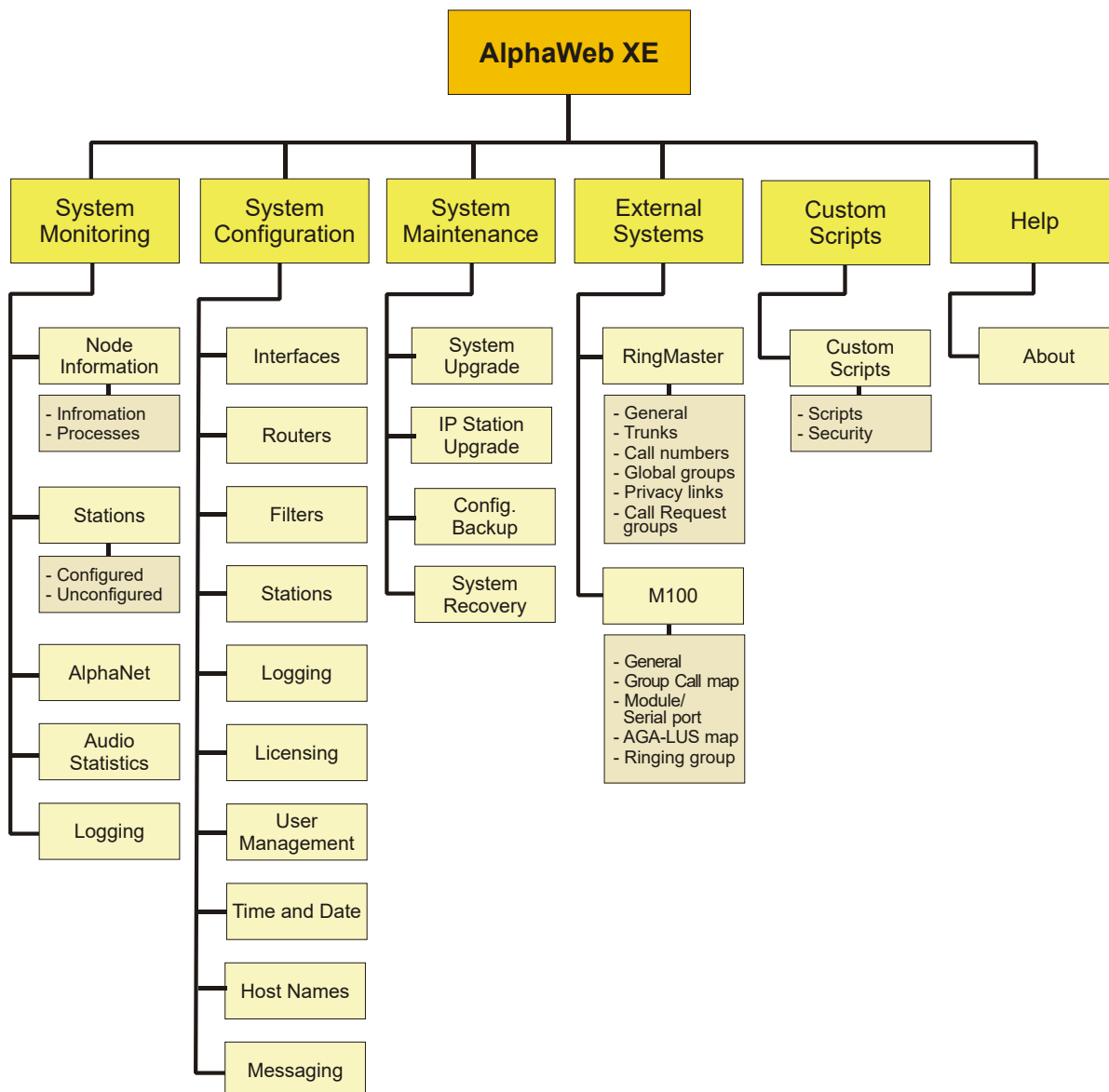

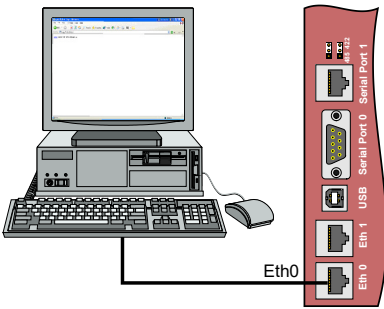

Figure 23 Connect PC to Eth0

### 6.1.1 Connecting to ACM using AlphaWeb

- Connect the PC Ethernet port to the LAN port (Eth0) on the ACM backplane.
  - Open your web browser to access AlphaWeb.
- ① *The factory default IP address of ACM exchange is 169.254.1.5. In order for your PC to communicate with the server, it is necessary to change its Internet Protocol Properties to use an IP address that is in the same range as 169.254.1.5, e.g. 169.254.1.10.*

- Enter **http://169.254.1.5** in the address field of the browser
  - Connection with the ACM is verified by the text:  
**[Login] Secure AlphaWeb (https)**  
**[Login] Unsecure AlphaWeb (http)**

- Click **Login** for **Unsecure AlphaWeb (http)**
  - unless encrypted access to the Internet is required for safety reasons

- The user will be prompted for a user name and password. The default login for a user with reading rights only is:

User name: **alpha**  
 Password: **com**

- To be able to change the configuration, the user must log in as an administrator. The default login will then be:

User name: **admin**  
 Password: **alphaadmin**

A window with exchange configuration information will be displayed:

The screenshot shows the AlphaWeb interface with a navigation menu at the top: System Monitoring, System Configuration, System Maintenance, External Systems, Custom Scripts, and Help. The 'System Monitoring' tab is active, and the 'Node Information' section is expanded to show 'Information'.

**Information**

Information	Status
Node Name	AlphaCom_1
Node Number	1
Operational	Enabled
Usage	Idle (0/250)
Current System Time	18:42:11
System Uptime	10 min
AMC Uptime	9 minutes, 59 seconds
MAC Address	00:13:CB:02:00:92
Total Space (FLASH / DATA FLASH / RAMFS)	30336 / 32768 / 20480 kB
Free Space (FLASH / DATA FLASH / RAMFS)	7472 / 31700 / 20264 kB
Battery valid	Yes

**SW Configuration**

Software	Release
AMC System Package	Version 11.1.3.4-d409M
AMC Board Support Package	Version 30.00
Customer Database	Version 11.00

**HW Configuration**

Search:  Display 15 records

Module (CC)	Board Position	Board Type	Board State	Board Version	Board SBI
Master (65)	25	AMC_3_05	OPERATING	11.1.3.4	4 x SBI_03
Master (65)	01	ASLT_0	OPERATING	03.00	1 x SBI_01
Master (65)	21	AGA_1	OPERATING		2 x SBI_02
Master (65)	26	APC_0	OPERATING		1 x SBI_02

Showing 1 to 4 of 4 entries

First Previous 1 Next Last

### 6.1.2 Saving and applying changes

When new configuration parameters are entered, they should be saved to the configuration file by clicking the **Save** button.

The configuration data is then saved to the ACM/AlphaCom configuration file only, and not applied to the running configuration. To make the new configuration data apply to the running configuration, click the **Apply** button.

## 6.2 AlphaPro - Getting Started

### 6.2.1 PC setup

- Start up the computer
- Download the latest AlphaPro version from the VINGTOR Partnetnet or insert the CD-ROM with the AlphaPro installation
- Select and run the file **installalphapro.exe**
- Follow the instructions on the screen
  - You can safely answer “**YES**” to all questions

### 6.2.2 Insert the HW dongle

- Insert the hardware dongle in the PC’s parallel port or USB port depending on the dongle type.
  - Leave the dongle in the PC during programming and transferring of data to the exchange.

If the dongle is not inserted, AlphaPro will run in AlphaPro M mode. You will still have access to all functions (except AlphaNet), but only for 36 subscribers.

### 6.2.3 AlphaPro Menu Structure

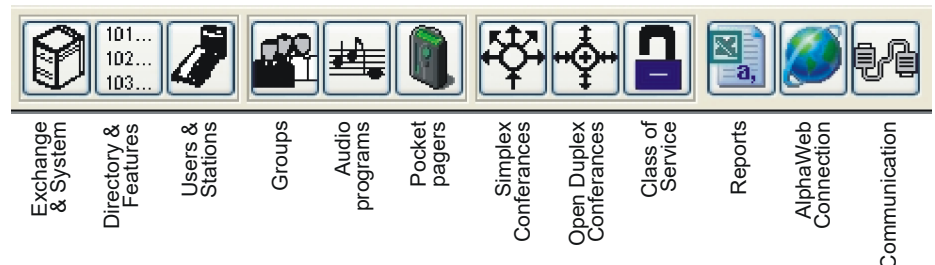

Use the menus in AlphaPro to change the default system setup. The menu bar at the top of the screen has 12 main menus accessed by clicking on its icon. Each main menu will have one or more selectable tabs or submenus.

AlphaPro may be run without being connected to ACM (off-line), and all changes can be saved to the PC and copied to the system later on.

It is good practice to start the programming in the **Exchange & System** menu and continue rightwards on the menu bar.

### 6.2.4 Creating a New Network and Exchange

When configuring the settings for an exchange for the first time, you need to create a new network and exchange. This will then create an AlphaPro configuration database.

#### Select network

- Click **[+]** next to the **Select Network** drop-down menu
- Enter a system name (customer/network name)
  - maximum 23 characters
  - do not use national characters like æ, ø, å, ä, é, etc.

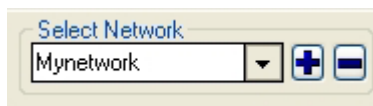

#### Select exchange

- Click **[+]** next to the **Select Exchange** drop-down menu
- Enter a node (exchange) name
  - maximum 16 characters
- Enter exchange node number
  - applies to AlphaNet nodes, otherwise enter 1
- Select the desired type of node (exchange)

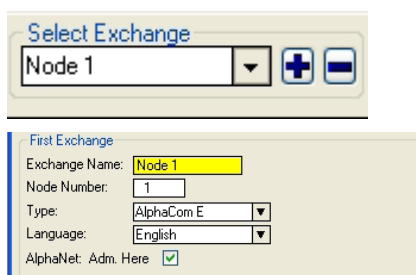

- Select the language for the exchange
- Check the **AlphaNet: Adm. Here** box
  - Creates an exchange with full database which can be configured from this PC.

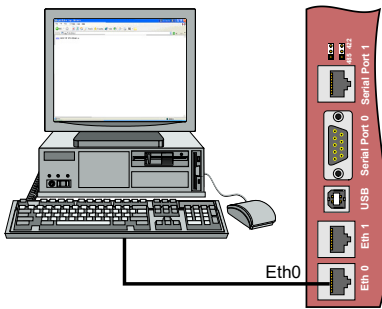

## 6.2.5 Data communication

In order to establish communication between the PC and the exchange, do the following:

### Connect the PC to ACM

- Connect the PC to the **Eth0** port in the ACM exchange
  - When the PC is connected to the ACM, the AlphaPro communication program can be opened.

① *During data transfer to the ACM exchange, it is not possible to modify configuration data in the ACM exchange.*

### Establish data communication



- Click the **Connection** icon
  - The Communication window appears
  - The connection is confirmed when the communication is established and the buttons will then become active.

### Send information to the exchange

When the desired changes to the programming are done, the new configuration database must be loaded into the exchange.



- Click **SendAll** to send all data
- Click on **SendChg** to send changed data only
  - An icon in the lower-right corner flashes during transmission.
- The transmission may be stopped by clicking **Cancel**
  - The **Cancel** key changes to **OK** when the transmission is finished.
- Click **OK**

### Get information from the exchange

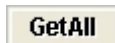

- Click **GetAll** to download the configuration database from the exchange.

# 7 Programming Guide

## 7.1 Programming Overview

The main steps for programming an ACM system are:

- Perform cold start
- Configure IP address
- Enter license key
- Configure general user settings (two-way communication)
- Configure handsfree two-way communication (talk-back)
- Configure Public Address
- Configure external communication

A complete programming reference is described in the *System Management Manual A100K10338*.

- ① *If an existing exchange configuration shall be modified, download the configuration from the exchange. See section 6.2.5. Do NOT perform a cold start!*

## 7.2 Perform Cold Start

A cold start of the AMC-IP board will delete all previous programming, load the default database and set the default IP address to **169.254.1.5** with subnet mask **255.255.0.0** on Eth0.

### 7.2.1 Cold start procedure

- Turn the exchange mains switch ON
  - auto-fuse at the rear of the cabinet
- Press and hold the cold start button on the AMC-IP board
- Press the reset button located on the power card briefly
- Keep the cold start button pressed at least 5 seconds after reset.
  - The AMC status LED will blink green when the boot is ready.

### 7.2.2 Cold start AMC application only (retain IP settings)

- Press the reset button located on the power card briefly
- After 10 seconds, press the cold start button on the AMC-IP board.
- Keep the cold start button pressed until the AMC running LED blinks green.

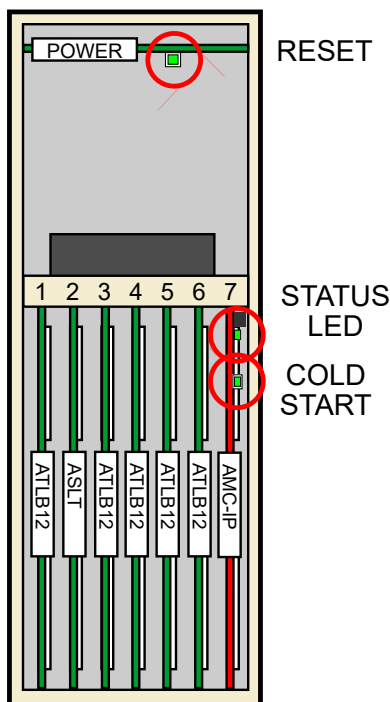

Figure 24 Cold start

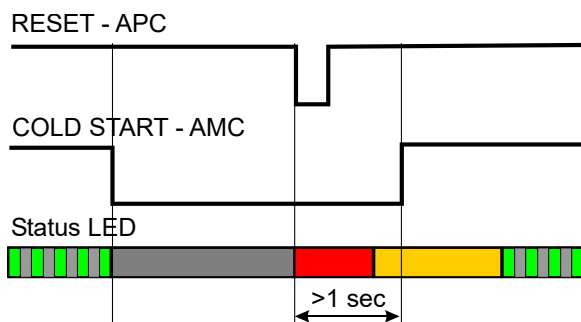

Figure 25 Cold start to load default database

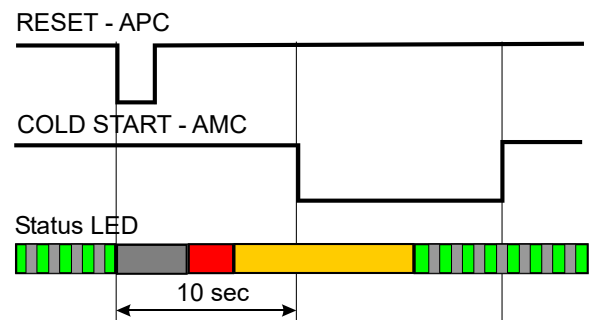

Figure 26 Cold start and keep IP settings

## 7.3 Configure IP Address

To connect the ACM exchange to your IP network, you need to enter the IP settings for the Ethernet ports and IP route entries according to the network. See *Section 5.3 ACM Programming and Cable Reference List* for IP settings to use.

### Set IP address for Ethernet port 0 and/or 1

Interface	IP Address				Subnet Mask			
eth0	169	254	1	5	255	255	0	0
eth1	10	5	11	39	255	255	255	0

Interface	IP Address	Subnet Mask	MAC Address
eth0	169.254.1.5	255.255.0.0	00:13:CB:02:00:92
eth1	10.5.11.39	255.255.255.0	00:13:CB:82:00:92

Configuration File	Last Saved	Last Applied
amc_ip_config.xml	2009-10-07 18:44:33	2010-04-22 04:45:52

- Log in to ACM via **AlphaWeb**
- Select **System Configuration > Interfaces**
- Enter the IP address
- Enter the subnet mask
- Click **Save** to save the values



**Do NOT click Apply until all address, routing and filter changes have been saved!**

Route Type	Destination IP	Destination Mask	Gateway	Out Interface	Action
default			10.5.2.1	eth0	Delete

Destination IP	Destination Mask	Gateway	Out Interface
169.254.0.0	255.255.255.0	*	eth1
10.5.2.0	255.255.255.0	*	eth0
default	0.0.0.0	10.5.2.1	eth0

Configuration File	Last Saved	Last Applied
amc_ip_config.xml	2010-03-11 11:40:30	2010-03-11 11:40:30

### Set IP Routes

Route type *host* is used to set up a route to a single device outside the subnet of ACM.

Route type *net* is used to set up a route to another network.

Route type *default* is used to set up a general route to any device outside the subnet of ACM.

- Select **System Configuration > Routes**
- Select the type of IP route by clicking **Add Route**
  - **Default IP route**  
Enter only **Gateway** (IP address) and **Out Interface** Ethernet port (eth0/1)
  - **Network route**  
Enter **Destination IP** address, **Destination Mask**, **Gateway** and **Out Interface** Ethernet port (eth0/1)
  - **Host route**  
Enter **Destination IP** address, **Gateway** and **Out Interface** Ethernet port (eth0/1)
- Click **Save** and **Apply** to apply changes

**Add a New IP-Route**

All form fields are required.

Route Type	default
Destination IP	net
Destination Mask	default
Gateway	
Out Interface	eth0

## 7.4 Enter License Key

Licensing

Search:

License Type	# of Licenses	Currently Used	Available	Rejections
Billing	0	0	0	0
CRM Stations	2	0	2	0
IP AlphaNet Lines	2	0	2	0
IP Stations	10	0	10	0
MSO	1	0	1	0
Multi Module	0	0	0	0
OPC server	40	4	36	0
ReCall	0	0	0	0
Ring Master	1	0	1	0
SIP Stations	2	0	2	0
SIP Trunk Lines	2	0	2	0

Showing 1 to 11 of 11 entries First Previous 1 Next Last

License Key

MAC Address  
00:80:35:03:23:D3

**Insert New License Key** ✕

All form fields are required.

Input License Key

Obtain the license key from your ACM distributor.

To install the license:

- Select **System Configuration > License Key**
- Click **Insert new License Key**
- Enter the key string in the **Input License Key** field
- Click **Insert Key** to install the license.

① *The ACM requires IP station licenses and SIP trunk licenses for the number of IP stations and external trunk lines the exchange shall support.*

## 7.5 Configure User Settings

This chapter describes how to program the system user and station directory in order to comply with marine requirement for emergency two way communication. The chapter is divided in the following parts:

- General user settings
- Program different class of service for users
- Program call priority

Before you will be able to program the user and station directory, the Program and Cable Reference List must have been filled in. See chapter 5 Programming and Cable Reference List.

### 7.5.1 General user settings



- Click on the **User & Stations** icon in AlphaPro.

The main fields for a normal configuration are:

- Physical Number
- Directory Number
- Display Text
- Station Type
- Volume Setting
- Group Access Level
- Call Setup Priority
- Class of Service

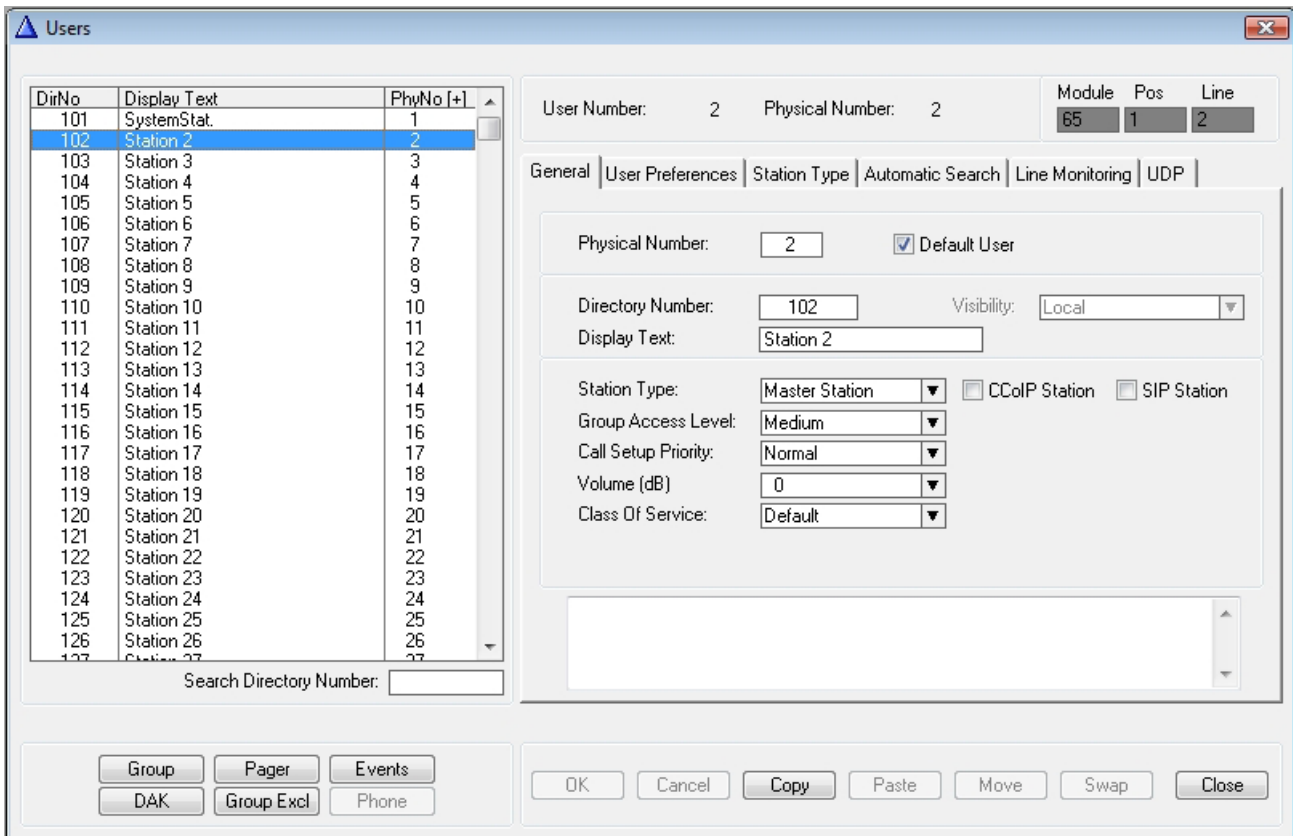

**Physical Number** All stations are identified by the exchange with its physical number. The physical number for a star-wired station is the number of the physical wire connection point on the ASLT or ATLB-12 card. See section 4.6.1 for overview of physical numbers.

**Directory Number** The number to dial to reach the station. The default number can be changed to any two to eight digit number starting with 1, 2, 3, 4 or 5. Numbers with the first digit from 6 to 9 are reserved for functions. If these numbers should be used, the corresponding function code must be changed.

**Display Text** The station ID text shown in the called station's display and system logs as well as for billing and DECT display. The text should normally be the station location or the subscriber's name. The max number of characters is 16 including the station directory number.

**Visibility** This can be set to **Local** or **Global**. Visibility is related to AlphaNet when cluster programming is used.

- **Local**: station can be addressed inside the node only.
- **Global**: station can be reached from all nodes in a cluster.

A cluster is a subnet of a network, and consists of a number of defined nodes.

**Station Type** Used to define the type of station on the actual physical number.

**Master Station** is the default option - this setting will automatically detect the connected type of station.

Analog telephones shall have station type **Master Station**.

**Sub Station** option should be selected for stations with limited keypad and lines used for interfacing Public Address amplifier system.

**Display Station** option can be selected to ensure faster and safer line error detection on display station lines.

Other special station options can be selected to obtain optimal performance and programming for the relevant stations.



**CCoIP** or **SIP** stations are selected by checking the appropriate box.

- Checking the **CCoIP Station** box results in a field for MAC address and a box for registration with directory number.
  - The latest ACM version can use both methods for identifying an IP station.

When configuring an IP station in AlphaPro, you must select which methods to use to identify the IP station. The advantage of using registration by directory number is that it is easier to replace the station at a later stage as this does not require new settings in AlphaPro.



### Directory Number registration

- This is the default registration for CCoIP stations.
- Check the **Reg. w/Directory Number** box to register the station.

### MAC address registration

- Uncheck the **Reg. w/Directory Number** box to bring up the MAC address field.
- Enter the station's MAC address.  
The MAC address can be found by logging into the web interface of the IP station or AlphaWeb under **System Monitoring > Stations > Unconfigured**.

### SIP Station

Check the **SIP Station** box if the station is a SIP telephone.

### **Group Access Level**

Used to specify which group and PA calls a user may make. Each group, used for group and PA calls, will have an associated **Group Access Level**. The levels are *Low*, *Medium* and *High*. The user must have a higher or the same group access level.

By default, the group used for emergency PA announcements are programmed as Group 1 with group access level *High*. Only users with group access level *High* can make an emergency PA announcement.

### **Call Setup Priority**

Used to specify how outgoing calls from the station shall be treated.

Priority	Low	Medium	High	Alarm
Call to an idle, open station	Rings	Connects	Connects	Connects
Call to station with private switch ON	Rings	Rings	Connects	Connects
Call to a station with absence message	Hears the message	Hears the message	Connects	Connects
Call to a busy station	Busy tone	Busy tone	Busy tone	Connects

Table 10 Call Setup Priority

**Call Setup Priority** is used to give special treatment to users that should never receive a busy tone, such as the bridge station and captain's station.

### **Volume**

Setting Used to compensate for volume loss on long lines, and to tune volume level according to marine requirements.

Available values are -14 dB to +16 dB. The default setting is 0 dB. This will be 'normal' volume setting in the station. For local regulation of the volume, use the volume control on the station.

The exchange must be reset if the volume setting has been changed.

**Class of Service** Determines which features in the system the station can activate.

There are 16 different classes available and each can be freely programmed. A Station can only have one Class of Service defined. The following classes have a Default setup (which can be changed):

- COS 1 Regular stations in the system
- COS 16 Includes all services. Default for SuperUser.

### 7.5.2 Program different class of service for users

An ACM system is usually programmed with the following Classes of Service:

- COS 1 Regular stations in the system
- COS 2 Notify busy station
- COS 5 Override of busy, absent, and private
- COS 16 Includes all services. Default for SuperUser

#### Create a new Class of Service



- Click on the **Class of Service** icon  
- The Class of Service window is opened

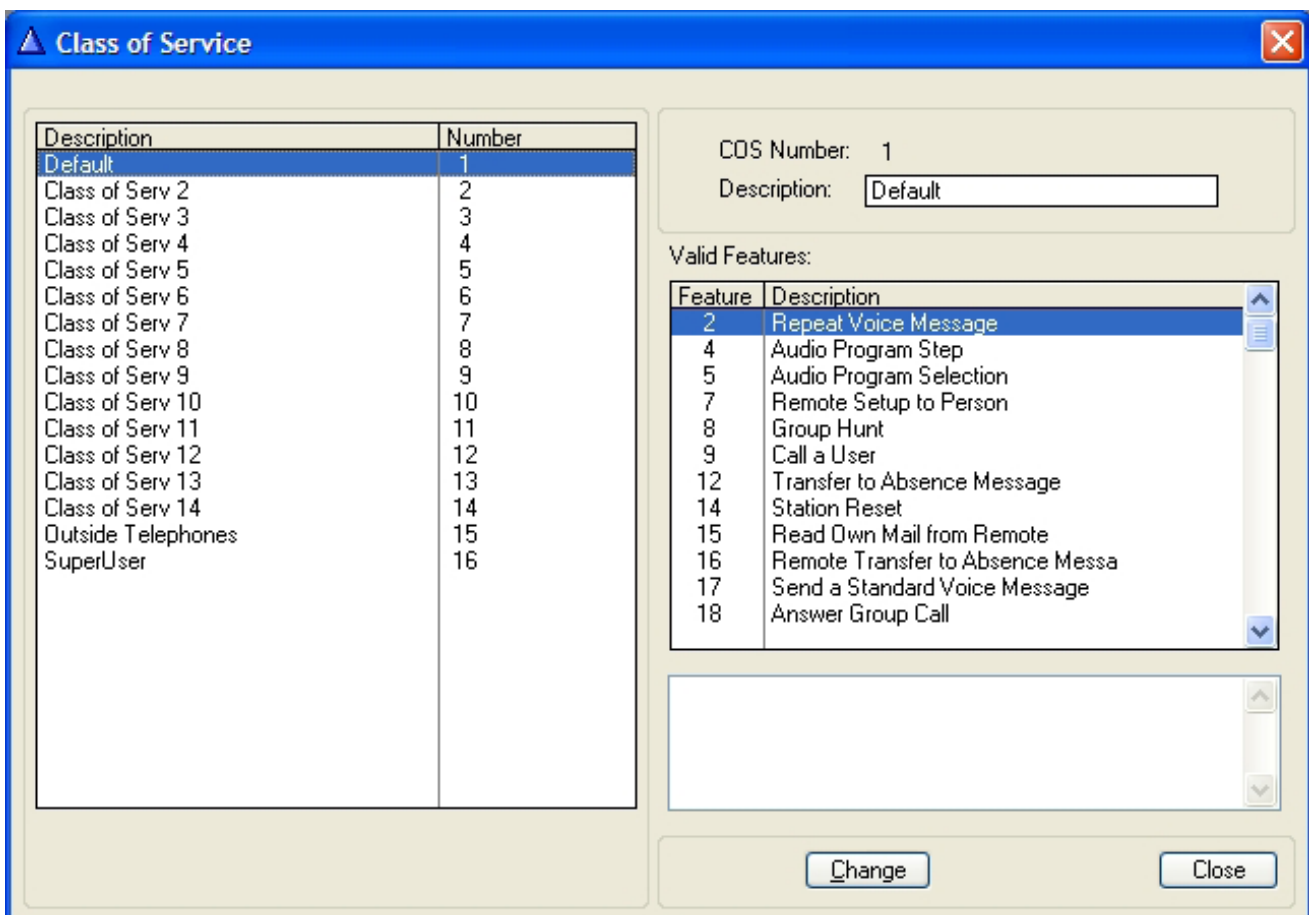

- Select the Class of Service you want to modify and click **Change**  
- A window to change the selected Class of Service is opened
- Click the **Copy from** button and select **Default**  
- The selected Class of Service gets the same service set as the default station (COS 1)
- Select the services you want to assign to the selected Class of Service
- Click **OK** when all services are selected.

When a change has been made to a directory number, the **OK** and **Cancel** buttons become active.

The settings for a station can be swapped with another station by doing the following:

1. Highlight the first station in the list
2. Click the **Copy** button and then highlight the second station
3. Click the **Swap** button to swap the two stations.

① *Ordinary analog telephones can be connected by using ATLB cards. No configuration is needed to make the phone function as an ordinary station. The Station Type is set to Master Station.*

## 7.6 Handsfree Two-Way Conversation (Talk-Back)

### 7.6.1 Overview

ACM systems can be programmed for handsfree two-way communication (Talk-Back) according to marine requirements.

#### Talk-Back units

The VMP430 or IP Master Flush Station is used as the main talk-back panel on the bridge. In other talk-back positions, the VMP503 and VMP530 intercom stations are used.

This section describes how to program the system for:

- directory
- bridge station (VMP 430)
- bridge station (IP Master Flush Station)
- other talk-back units

#### Talk-Back functions

The ACM talk-back systems consist of the following main user functions:

- Establish talk-back group
  - Call from bridge to other talk-back member
  - Call from other talk-back member to bridge
  - Volume control
  - Close talk-back group
- ① *When the bridge station user establishes the talk-back group, the subscriber line for the bridge station is fed into an ACM audio program input. In this case, the subscriber line is connected to program input 1.*

## 7.7 Configuring Public Address and General Alarm

### 7.7.1 Overview

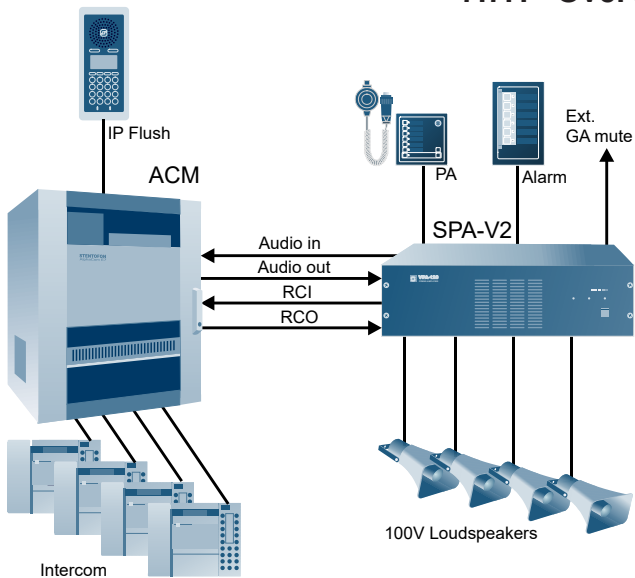

The ACM system supports the VINGTOR integrated PA and GA solution. Together with the VINGTOR SPA-V2 system, the ACM intercom stations are used to cover areas where PA and GA are required onboard the ship.

The figure shows an overview of the VINGTOR integrated PA and GA solution with the ACM and SPA-V2 systems.

#### **Public Address and General Alarm panels**

The following units can be used as PA and GA panels:

- SPA-V2 Public Address panels
- SPA-V2 General Alarm panels
- IP Flush Master intercom panel

Figure 27 Integrated PA & GA Overview

By default, the priorities between the different panels are:

- Pri 1: ACM intercom panel configured as emergency PA panel
- Pri 2: SPA-V2 Public Address panel
- Pri 3: SPA-V2 alarm panels
- Pri 4: Other ACM intercom stations

① *It is possible to switch the priority between SPA-V2 Public Address panels and ACM intercom panels based on customer requirements.*

#### **Loudspeaker solution**

ACM intercom stations used in two-way voice communication can broadcast PA and GA announcement. When a PA or GA message is played in an intercom station, these will be done with volume override in order to override any volume setting by the user.

#### **Interface ACM to SPA-V2**

A normal subscriber (user) extension is used as the interface from the ACM system to the SPA-V2 system.

At each subscriber position, the ACM has a remote control output where RCO1 is at subscriber position 1 and so on. The RCOs are used to signal PTT and SPA-V2 zone selection.

#### **Interface SPA-V2 to ACM**

The audio from the SPA-V2 comes in on the ACM program input (default program input 5).

The ACM exchange has a set of remote control inputs (RCIs) which is used to signal that PA and GA messages are available at the program input.

This section describes how to configure the system for:

- ACM PA zones
- interface ACM to SPA
- interface SPA to ACM

- IP Flush Master as PA panel
- Audio volume adjustment
- Handling of feedback
- PA broadcast of pre-defined messages

### 7.7.2 Configure audio interface from SPA-V2 to ACM

The audio interface from the SPA system is connected to the ACM program input. The ACM remote control input RCI 1 is triggered by the SPA system to make it so that audio from SPA is played either as a GA announcement or emergency PA announcement.

#### Select program



Program Number:	5
Description:	Program 5
Program Over Conversation	<input checked="" type="checkbox"/>
Volume/Handset Override	<input checked="" type="checkbox"/>

- Click the **Audio Programs** icon
- Select the audio program input to be used from the list, normally **Program 5**
- Click **Change**
- Check the **Program Over Conversation** and **Volume/Handset Override** boxes
- Click **OK**

#### Set the RCI 1 event in station 5000

To be able to program all features, a dummy number has to be made in the exchange and the event connected to this number since an RCI string can only contain up to 40 characters.

The following RCI programming will trigger an event type 15 (**Event Trigger Feature**) in the event handler, where station 5000 (physical no. 400) is the event owner and directory number 5001 is the "Related to" number.

The actual commands to be executed are programmed in the event handler.



RCI Number:	1
Description:	Input 1
Device:	65 65 = Exchange
Pin Number:	1
ON Action:	\$ER U15 U0 U1 U1 L5000 U3 L5001
OFF Action:	\$ER U15 U0 U0 U1 L5000 U3 L5001
On when Closed	<input checked="" type="checkbox"/> (Normal Open)
Delay Before ON Action:	0,0 (sec)
Activate Faulty Module LED	<input type="checkbox"/>

- Click the **Exchange & System** icon
- Click **RCI**
- Select **Input 1** (RCI 1) to be used to signal audio from SPA
- Click **Change**
- In the **ON Action** field, enter:  
`$ER U15 U0 U1 U1 L5000 U3 L5001`  
*Triggers event type 15, subevent 0, When Change To = ON, Owner = station 5000, Related To = directory number 5001*
- In the **OFF Action** field, enter:  
`$ER U15 U0 U0 U1 L5000 U3 L5001`  
*Triggers event type 15, subevent 0, When Change To = OFF, Owner = station 5000, Related To = directory number 5001*
- Check the **Normal Open** box
- Leave **Delay Before ON Action** at **0.0** sec.
- Enter a descriptive text, e.g. *Signal audio from SPA*
- Click **OK**

#### Set the ON event

This programming will disable feature no. 5 - *Audio program selection* from class of service for group no. 1, 2, 3, 4, 5, 16. It will not be possible to dial C or 800 to these groups in order to prevent PA audio on the intercom station. An audio connection will be set up from input no. 5 to

group 10. Also, any ongoing conversation between stations in the ACM-system will be cancelled.



**Owner**

Owner Type: Station Id: 400 Id: 400  
5000 Station 400

**Event**

Event Type: 15 - Event Trigger Feature Details  
Sub Event: 0

When Change To: ON

When Related To: Directory Number  
Node: Id: 5001

Action: Command or RCD

Command  
\$MCC U1 U5 U0  
\$MCC U2 U5 U0  
\$MCC U3 U5 U0

RCD

- Click the **Exchange & System** icon
- Click **Events**
- Click **Insert**
- Select **Station Id** from the **Owner Type** drop-down list, and enter **400** in the **Id** field.
- Select **15 - Event Trigger Feature** from the **Event Type** drop-down list
- Select **ON** from the **When Change To** drop-down list
- Select **Directory Number** from the **When Related To** drop-down list
- Enter **5001** in the **Id** field
- Select the **Action: Command** radio button
- Enter the following event strings in the adjacent field:  
\$MCC U1 U5 U0  
\$MCC U2 U5 U0  
\$MCC U3 U5 U0  
\$MCC U4 U5 U0  
\$MCC U5 U5 U0  
\$MCC U16 U5 U0  
PRG 10 5  
\$CAC U10
- Click **OK**

### Set the OFF event

The programming will first turn off the audio from input no. 5 to group 10. Then the program selection in class of service to group 1, 2, 3, 4, 5, 16 will be restored.



**Owner**

Owner Type: Station Id: 400 Id: 400  
5000 Station 400

**Event**

Event Type: 15 - Event Trigger Feature Details  
Sub Event: 0

When Change To: OFF

When Related To: Directory Number  
Node: Id: 5001

Action: Command or RCD

Command  
PRG 10 0  
\$MCC U1 U5 U1  
\$MCC U2 U5 U1

RCD

- Click the **Exchange & System** icon
- Click **Events**
- Click **Insert**
- Select **Station Id** from the **Owner Type** drop-down list, and enter **400** in the **Id** field.
- Select **15 - Event Trigger Feature** from the **Event Type** drop-down list
- Select **OFF** from the **When Change To** drop-down list
- Select **Directory Number** from the **When Related To** drop-down list
- Enter **5001** in the **Id** field
- Select the **Action: Command** radio button
- Enter the following event strings in the adjacent field:  
PRG 10 0  
\$MCC U1 U5 U1  
\$MCC U2 U5 U1  
\$MCC U3 U5 U1  
\$MCC U4 U5 U1  
\$MCC U5 U5 U1  
\$MCC U16 U5 U1
- Click **OK**

### PA audio group

This enables all stations that should be listening to the PA audio in group 10. In most cases this includes all stations.

Do not include the PA initiating stations in this group.



Group Number: 10  
 Descriptive Name: Station Group 10

Directory Number: 894  
 Display Text: PA call

Group Access Level: High  
 Setup Priority: High  
 Gong Type: No Gong  
 Max. Missing Members: 0 Answer

Remember to add members in this alarm group.

- Click the **Groups** icon and select **Local Groups**
- Select the **Group Call** radio button
- Select **Station Group 10** from the list
- Click **Change**
- Enter a descriptive text, e.g. *PA call* in the **Display Text** field
- Set **Group Access Level** to **High**
- Set **Setup Priority** to **High**
- Set **Gong Type** to **No Gong**
- Leave **Max. Missing Members** at **0**
- Uncheck the **Answer** box
- Click the **Members** tab
- Select the group members from the **Not Members** list
  - Use the double right-arrow button to transfer all stations in the list to the **Members** list
  - Use the single left-arrow button to exclude stations, like the PA initiating stations, from the **Members** list
- Click **OK** to update records

General Members

Group Number: 10  
 Descriptive Name: Station Group 10

Not Members			Members		
Dir. no	Display Text	Station No	Dir. no	Display Text	Station No
103	Station 3	3	101	SystemStat.	1
104	Station 4	4	102	Station 2	2
			105	Station 5	5
			106	Station 6	6
			107	Station 7	7
			-	< User 8	8
			109	Station 9	9
			110	Station 10	10
			111	Station 11	11
			112	Station 12	12
			113	Station 13	13
			114	Station 14	14

### 7.7.3 Configure ACM PA zones

The ACM system can assign the different ACM intercom stations into groups.

To configure multiple PA zones, the ACM intercom stations that are used for PA announcements in the zones need to be defined as a group.

#### Configure 'All Stations' group

Group Number: 1  
 Descriptive Name: All Station

Directory Number: 84  
 Display Text: AllCall

Group Access Level: High  
 Setup Priority: Alarm  
 Gong Type: Dong Ding  
 Max. Missing Members: 0 Answer

- Click the **Groups** icon and select **Local Groups**
  - Select **All Stations** from the list
  - Click **Change**
  - Set **Setup Priority** to **Alarm**
  - Enter the number for All Stations group in the **Directory Number** field (default is **84**)
  - Click **OK**
- ① *A group call with priority alarm will use volume and handset override. The group call will be set up even if the stations are in*

conversation, has absence messages or are in private mode.  
See Table 9 Call Setup Priority.

### Configure other PA zones



Group Number:	2
Descriptive Name:	Station Group 2
Directory Number:	86
Display Text:	GroupCall 2
Group Access Level:	Medium
Setup Priority:	Normal
Gong Type:	Ding Dong
Max. Missing Members:	0 Answer <input checked="" type="checkbox"/>

- Click the **Groups** icon and select **Local Groups**
- Select the applicable **station group** from the list
- Click **Change**
- Click the **Members** tab
- Select the group members from the **Not Members** list
  - Use the double right-arrow button to transfer all stations in the list to the **Members** list
  - Use the single left-arrow button to exclude stations, like the PA initiating stations, from the **Members** list
- Click the **General** tab
- Enter the directory number for the group in the **Directory Number** field (default is **85-88**)
- Click **OK**

## 7.7.4 Configure audio interface ACM to SPA-V2

### Select RCO for Push-to-Talk



A normal subscriber (user) extension is used as the interface from the ACM system to the SPA system. At each subscriber position, the ACM has a remote control output where RCO 1 is at subscriber position 1 and so on. The RCO is used to signal PTT and zone selection to the SPA-V2 system.

107	Station 7	7
108	< Phys. No 8	8
109	Station 9	9
110	Station 10	10

Owner	
Owner Type:	Station Id: 8 108 < Phys. No 8
Event	
Event Type:	1 - Audio
Sub Event:	126
When Change To:	ON or OFF
When Related To:	All
Node:	Id: 0
Action: Command or RCO	
<input type="radio"/>	
<input checked="" type="radio"/>	RCO 1 RCO

- Click the **Users & Stations** icon
- Select the subscriber station used as the interface to the SPA system from the list
- Click **Events**
- Click **Insert**
- Select **1 - Audio** from the **Event Type** drop-down list
- Enter **126** in the **Sub Event** field
- Select the **RCO** to be used to control PTT from the drop-down list
- Click **OK**

### Volume adjustment ACM intercom stations

- See section 7.5.1 on how volume is set on VMP intercom stations.
- ① *The ACM system will, by default, activate 'volume override' and 'handset override' for an announcement made to a group when the Call Setup Priority is set to ALARM for the station making the announcement.*

### Muting PA



When All Call is activated from the ACM system, an ongoing alarm from the PA system is supposed to be muted. Also, any ongoing conversations between stations in the ACM system will be cancelled. This feature must be enabled as the ACM will not do this by default.



- Click the **Exchange & System** icon
- Click **System**
- Click the **Calls and Options** tab
- Check the **Mute Program During Group Call** box under **Flags** - Audio from program (PA) and All Call (ACM) will be mixed and cause acoustic feedback if this flag is not set.
- Uncheck the **Ringling Group in Global mode** box
- Set the **Private ring mail priority** value to **150**
- Leave all other parameters with their default values

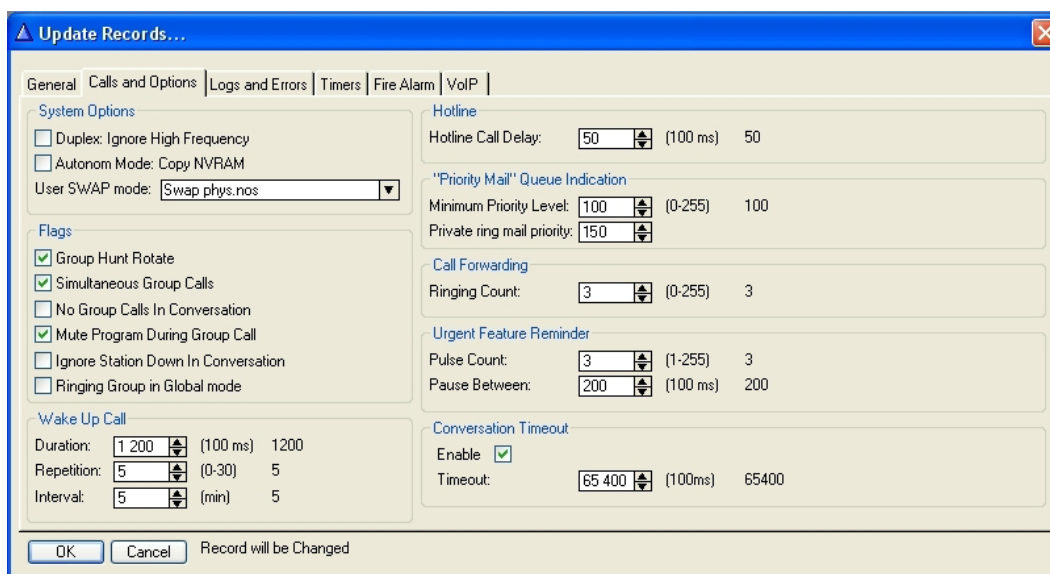

### Set UDP events

UDP8 is active as standard on all telephones. The owner is therefore UDP8 related to directory no. 84 (Group Call). If any station starts up an outgoing conversation (Event type 8) by selecting 84, this event will start.

This programming will activate three events in the system:

- The loudspeaker in the station who has enabled the action will be disabled when the handset is active, and automatically enabled when the handset is not active.
- Program distribution will be turned off in the station that activated the event, and turned on when the event is disabled.
- Remote Control Output no. 1 (RCO 1) will be activated. This is a dry contact output that will activate All Call in the PA system.

Other groups in SPA can be activated by changing directory no. 84 by other group numbers and other RCOs.

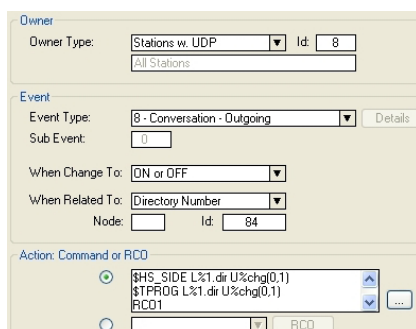

- Click the **Exchange & System** icon
- Click **Events**
- Select **Stations w. UDP** from the **Owner Type** drop-down list, and enter **8** in the **Id** field
- Set **Event Type** to **8 - Conversation - Outgoing**
- Set **When Change To** to **ON or OFF**

- Set **When Related To** to **Directory Number**
- Enter **84** in the **Id** field
- Select the **Action: Command** radio button
- Enter the following event strings in the adjacent field:
 

```
$HS_SIDE L%1.dir U%chg(0,1)
$TPROG L%1.dir U%chg(0,1)
RCO1
%chg($CAC U1,)
```
- Confirm by clicking **OK**

### 7.7.5 Feedback – Intercom as PA panel

- ① *A PA system may experience audio feedback if a speaker is in the vicinity of the PA panel where the PA announcement is made.*

#### Mutual exclusion



It is possible to exclude defined neighboring intercom stations from receiving PA announcements. This will ensure that no feedback loop is open between the PA panel and the other intercom stations.

1:	5	▼
2:	6	▼
3:	9	▼
4:	0	▼
5:	0	No Physical Number
6:	1	108 Station 8
7:	2	101 SystemStat.
8:	4	102 Station 2
	5	104 Station 4
	6	105 Station 5
	7	106 Station 6
	9	107 Station 7
	10	109 Station 9
		110 Station 10

- Click the **Users & Stations** icon
- Select the **subscriber position** used as PA panel from the list
- Click **Group Excl**
- Select the **neighboring intercom stations** from the drop-down lists
- Click **OK**

### 7.7.6 Delayed PA Message - Recall

The ACM **Recall** feature enables the user to record, check, and play a live PA broadcast call.

By using delayed playback, audio feedback problems are avoided as no microphones are active at the time of the PA broadcast.

To carry out a delayed PA broadcast, do the following on a station with **Recall** enabled:

1. Dial the access number to a group
2. Press and hold down the **M-key**
3. Record a PA message by talking into the station microphone
3. Release the **M-key** to listen to the recorded message before dispatch
4. Press the **M-key** again to re-record the message or press the **C-key** (on-hook) to dispatch the message.

# 8 ACM System Racks Specifications

## 8.1 ACM-M-A-V2

Dimension (mm)	600W x 600H x 350D
Weight	45 kg
Mounting	Wall mounted
Temperature range	0 - 55°C (recommended 18 - 25°C)
Power	230 VAC mains; max. power 260 W 24 VDC emergency; max power 260 W Automatic switch-over between mains and emergency
IP class	IP 20
Subscriber capacity	60 analog telephones
Call capacity	Max. 12 concurrent calls
PA interface	0 dB/600Ω audio 1 relay to signal PA calls
External interface & Billing	Option: Analog telephone gateway Option: GSM telephone gateway Option: VINGTOR Billing system Option: Audio Messaging
IP multi-module	Up to 2 system racks
Data interfaces	2 x 10/100 Mbps Ethernet AutoMDIX 1 x RS232 serial data
Data networking	Option: 4 port industrial data switch
IP protocols	IP unicast - IP multicast - IP v4 - TCP - UDP - Telnet - FTP - TFTP - NTP - HTTP - HTTPS - Syslog - SNMP v2c - SIP - RTP - RTCP - VoIP AlphaNet - STENTOFON data - OPC
Remote system management	AlphaPro over IP Web

## 8.2 ACM-M-D

Dimension (mm)	600W x 600H x 350D
Weight	45 kg
Mounting	Wall mounted
Temperature range	0 - 55°C (recommended 18 - 25°C)
Power	230 VAC mains; max. power 260 W 24 VDC emergency; max power 260 W Automatic switch-over between mains and emergency
IP class	IP 20
Subscriber capacity	72 analog telephones or 36 intercom stations
Call capacity	Max. 12 concurrent calls
PA interface	0 dB/600Ω audio 1 relay to signal PA calls
External interface & Billing	Option: Analog telephone gateway Option: GSM telephone gateway Option: VINGTOR Billing system Option: Audio Messaging
IP multi-module	Up to 2 system racks
Data interfaces	2 x 10/100 Mbps Ethernet AutoMDIX 1 x RS232 serial data
Data networking	Option: 4 port industrial data switch
IP protocols	IP unicast - IP multicast - IP v4 - TCP - UDP - Telnet - FTP - TFTP - NTP - HTTP - HTTPS - Syslog - SNMP v2c - SIP - RTP - RTCP - VoIP AlphaNet - STENTOFON data - OPC
Remote system management	AlphaPro over IP Web

### 8.3 ACM-48-V10

Dimension (mm)	600W x 746H x 573D
Weight	70 kg
Mounting	Wall or floor mounted
Temperature range	0 - 55°C, recommended 18 - 25°C
Power	230 VAC mains with auto switch-over to 230 VAC emergency. Option 230 VAC mains with auto switch-over to 24 VDC emergency.
IP class	IP-20
Subscriber capacity	Pre-wired for 11 subscriber line boards or 66 intercom stations 552 subscriber extensions
Integrated PA & GA interface	6 relay outputs (control signal) 6 inputs (control signal) 4 audio channels out 6 audio channels in PA zone selection require custom programming
Remote control	6 relay outputs to drive signal units Option for additional 2 relay cards
Audio technology	Highresolution 1-Bit audio (18.5kHz) – Wideband IP audio (8kHz) – adaptive jitter buffers
External interface & Billing	Option: analog telephone gateway Option: GSM telephone gateway Option: VINGTOR Billing system Option: Audio Messaging
IP multi-module	Up to 2 ACM exchange racks
Data interfaces	2 x 10/100 Mbps Ethernet AutoMDIX 1 x RS232 serial data
Data networking	Option 4 port industrial data switch
IP protocols	IP unicast - IP multicast - IP v4 - TCPUDP - Telnet - FTP - TFTP - NTP - HTTP - HTTPS - Syslog - SNMP v2c - SIP - RTP - RTCP - VoIP AlphaNet - STENTOFON data - OPC
Remote system management	AlphaPro over IP Web

### 8.4 ACM-144-V10

Dimension (mm)	800W x 1250H x 600D
Weight	180 Kg
Mounting	Floor mounted
Temperature range	0 - 55°C, recommended 18 - 25°C
Power	230 VAC mains with auto switch-over to 230 VAC emergency. Option 230 VAC mains with auto switch-over to 24 VDC emergency.
IP class	IP-20
Subscriber capacity	Pre-wired for 17 subscriber line boards or 102 intercom stations 552 subscriber extensions
Integrated PA and GA interface	6 relay outputs (control signal) 6 inputs (control signal) 4 audio channels out 6 audio channels in PA zone selection require custom programming
Remote control	12 relay outputs to drive signal units. Option for additional 3 relay cards
Audio technology	Highresolution 1-Bit audio (18.5kHz) – Wideband IP audio (8kHz) – adaptive jitter buffers
External interface & Billing	Option: analog telephone gateway Option: GSM telephone gateway Option: VINGTOR Billing system Option: Audio Messaging
IP multi-module	Up to 2 ACM exchange racks
Data interfaces	2 x 10/100 Mbps Ethernet AutoMDIX 1 x RS232 serial data
Data networking	Option 4 port industrial data switch
IP protocols	IP unicast - IP multicast - IP v4 - TCPUDP - Telnet - FTP - TFTP - NTP - HTTP - HTTPS - Syslog - SNMP v2c - SIP - RTP - RTCP - VoIP AlphaNet - STENTOFON data - OPC
Remote system management	AlphaPro over IP Web

## 8.5 AACM-144-V10

Dimension (mm)	800W x 1250H x 600D
Weight	180 Kg
Mounting	Floor mounted
Temperature range	0 - 55°C, recommended 18 - 25°C
Power	230 VAC mains with auto switch over to 230 VAC emergency. Option 230 VAC mains with auto switch-over to 24 VDC emergency
IP class	IP-20
Subscriber capacity	Pre-wired for 23 subscriber line boards or 138 intercom stations 552 subscriber extensions 204 analog telephones
Integrated PA and GA interface	6 relay outputs (control signal) 6 inputs (control signal) 4 audio channels out 6 audio channels in PA zone selection require custom programming
Remote control	18 relay outputs to drive signal units. Option for additional 4 relay cards
Audio technology	High resolution 1-Bit audio (18.5 kHz) – Wideband IP audio (8 kHz) – adaptive jitter buffers
External interface & Billing	Option: analog telephone gateway Option: GSM telephone gateway Option: VINGTOR Billing system Option: Audio Messaging
IP multi-module	Up to 4 ACM exchange racks
Data interfaces	2 x 10/100 Mbps Ethernet AutoMDIX 1 x RS232 serial data
Data networking	Option: 4 port industrial data switch
IP protocols	IP unicast - IP multicast - IP v4 - TCPUDP - Telnet - FTP - TFTP - NTP - HTTP - HTTPS - Syslog - SNMP v2c - SIP - RTP - RTCP - VoIP AlphaNet - STENTOFON data - OPC
Remote system management	AlphaPro over IP Web

## 8.6 ACM-M-D/IP72 & ACM-M-D/IP96

Dimension (WxHxD) (mm)	ACM-M-D/IP72: 600 x 1150 x 600 mm ACM-M-D/IP96: 600 x 1350 x 600 mm
Weight	ACM-M-D/IP72: Approx. 107kg (without switches or accessories) ACM-M-D/IP96: Approx. 117kg (without switches or accessories)
Material	Powder coated steel RAL7035
Mounting	Floor mounted
IP class	IP-22
Temperature range	0-55°C, recommended 18-25°C
Power supply	230V AC Mains with switchover to 230V AC UPS (115V AC optional)
Power consumption	Without switches and no accessories: ~1A @ 230V AC / ~2A @ 115V AC. Please see power consumption for accessories to calculate total power consumption
Subscriber capacity	ACM-M-D/IP72: Up to 72 PoE devices internally ACM-M-D/IP96: Up to 96 PoE devices internally Max 552 subscribers with external sub racks
Space for optional equipment	ACM-M-D/IP72: 3HU 19" reserved for data switches, additional 3HU 19" rack mounted equipment ACM-M-D/IP96: 4HU 19" reserved for data switches, additional 4HU 19" rack mounted equipment
PA interface	1 audio out 0dB, 1 potential-free switch (all-call), 6 Potential free normal open outputs for zone selection (optional), 2 Program audio inputs (optional)
Radio interface	Audio in - Switch in - Audio out - Switch out, 1 set per IP-ARIO (optional)
Remote control	6 relay outputs per IP-ARIO (optional)
Data networking	3 types of PoE LAN switches available: Low power, Mid power or High power versions
Data interfaces	2 x 10/100 Mbps Ethernet Auto MDX (RJ45), 1x RS232 serial data (9-pin DIN), 1x RS232/-485/-422 serial data (RJ45)
Audio codecs supported	G.711 / G.722
IP protocols	IP unicast - IP multicast - IP v4 - TCP - UDP - Telnet - FTP - TFTP - NTP - HTTP - HTTPS - Syslog - SNMP v2c - SIP - RTP - RTCP - VoIP AlphaNet - STENTOFON data - OPC
Remote system management	AlphaPro over IP, AlphaWeb, Billing

## 8.7 Environmental Requirements

The ACM system has been tested and fulfills all requirements according to EN 60945 and IACS E10 standards.

- Rack Temperature: 0°C to +55°C
- Humidity: >95% RH @ 25°C / 93% RH @ 55°C
- Compass safety: Distance to ACM rack: 325 cm  
Distance to telephones: 95 cm

- ① *It is strongly recommend to install the rack in a ventilated technical instrument room with temperatures between 18°C and 25°C. This will extend system lifespan.*

# 9 Appendix A - Example Configuration Diagrams

## 9.1 Two-Way Communication

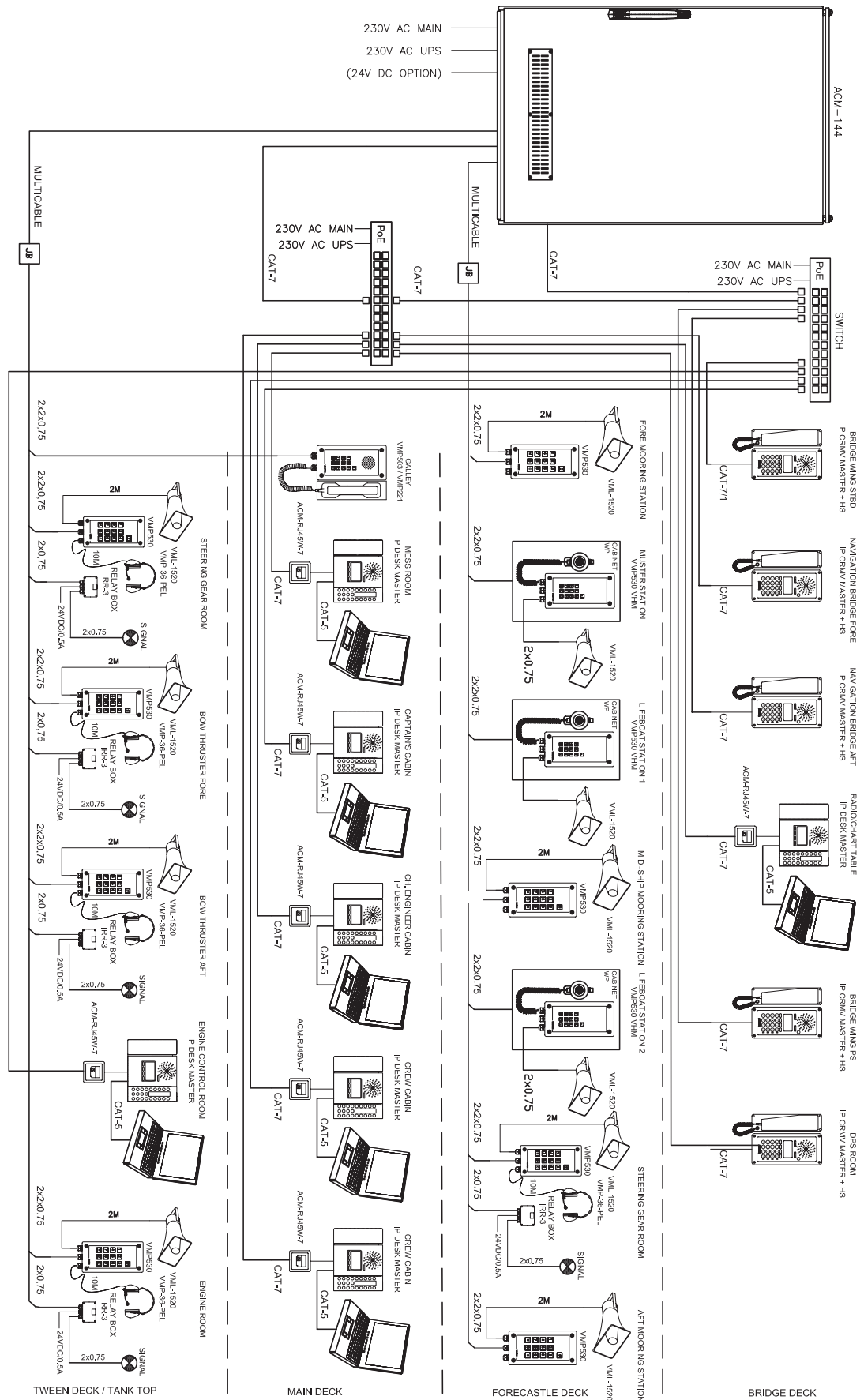

Figure 28 Example configuration - Two-Way communication

## 9.2 Public Address on Conventional Vessels

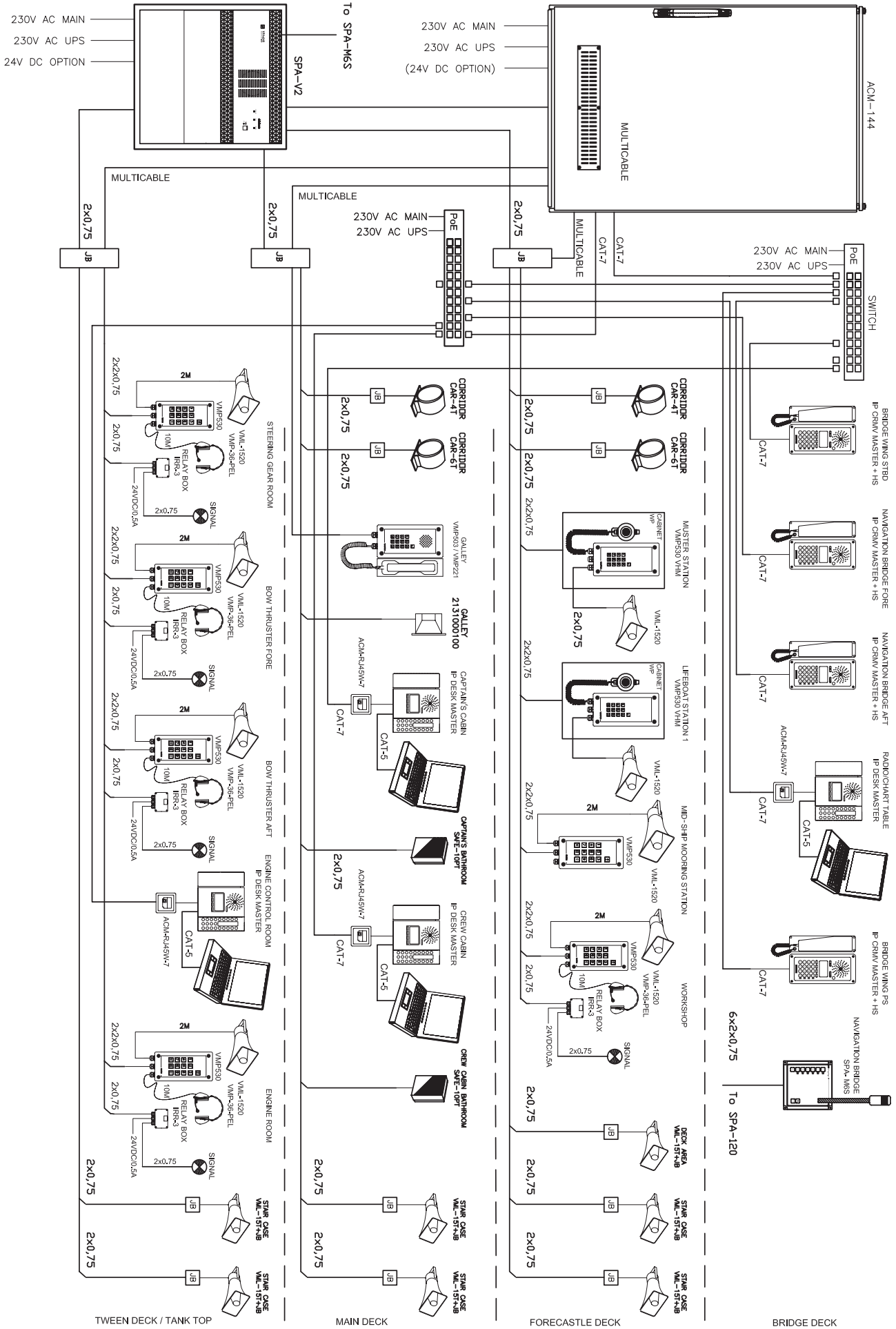

Figure 29 Example configuration - Public Address on conventional vessels



### 9.3 Integrated Public Address and General Alarm

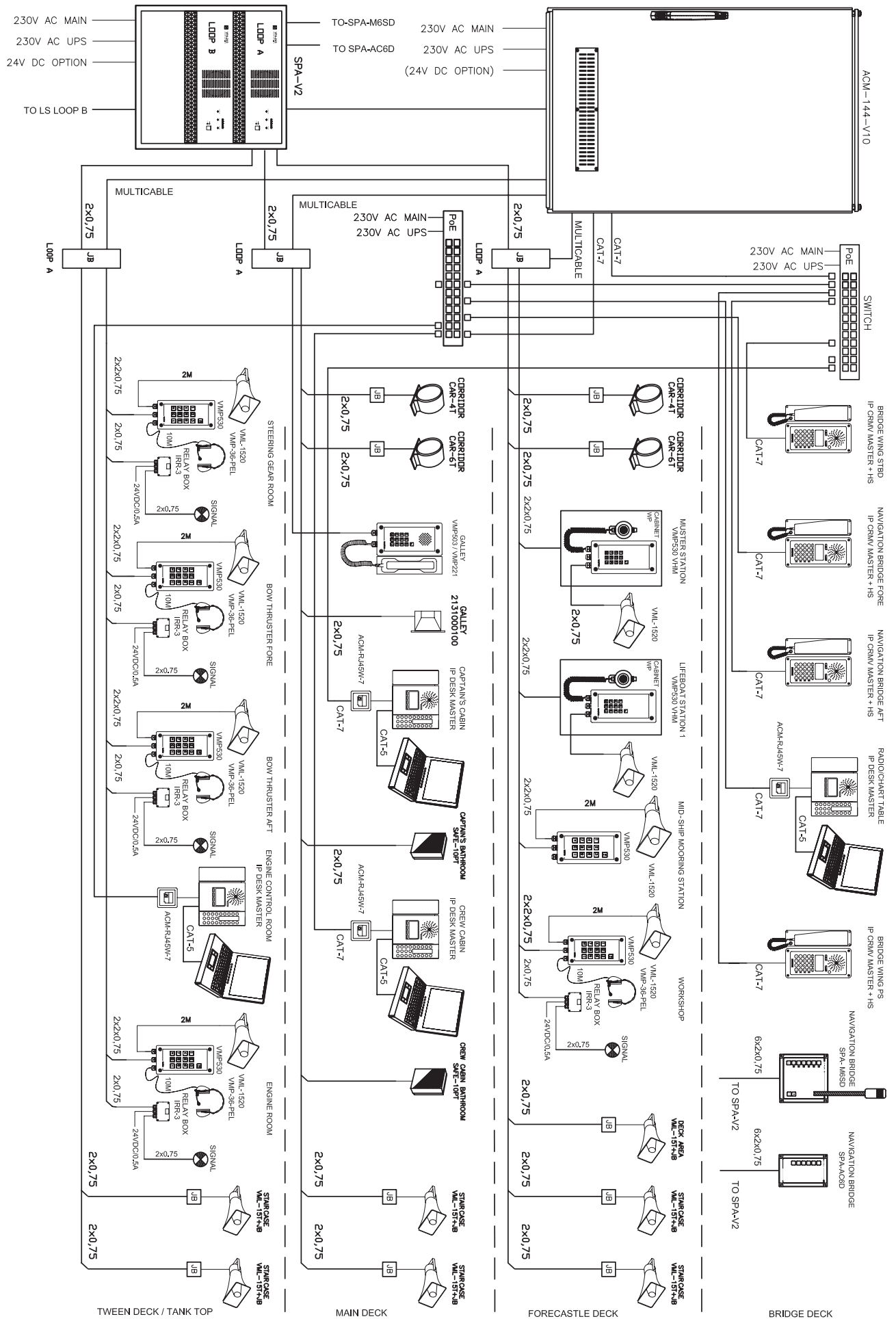

Figure 30 Example configuration of Integrated PA & GA - Loop A

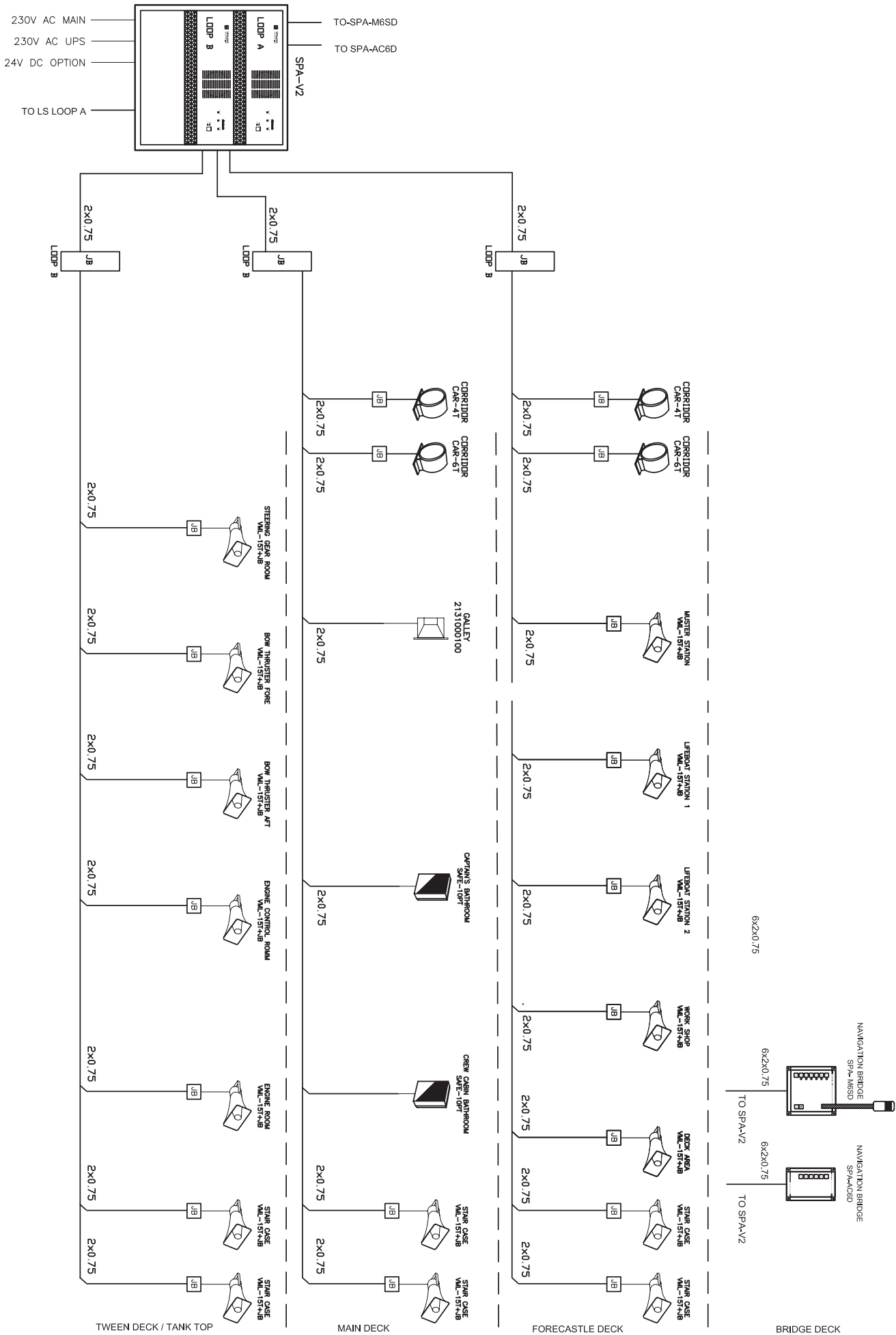
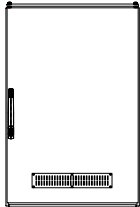
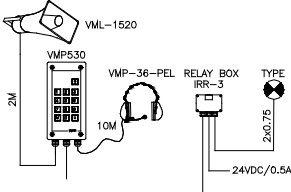
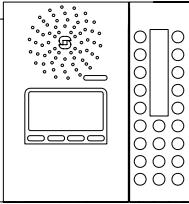
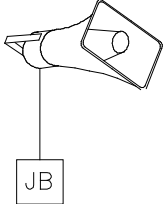
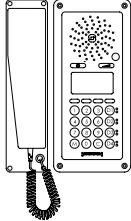
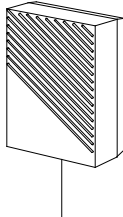
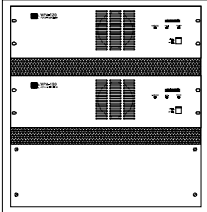
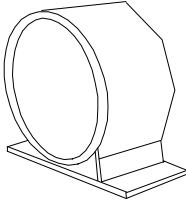
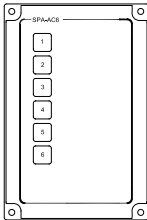
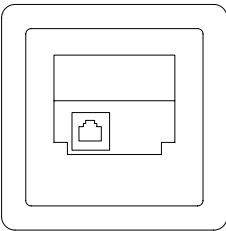
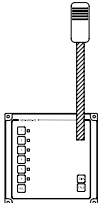

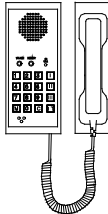
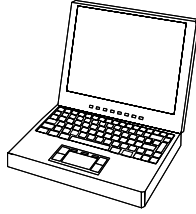
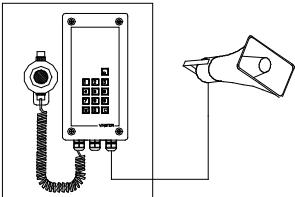
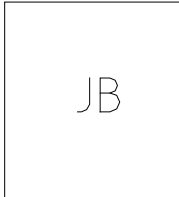

Figure 31 Example configuration of Integrated PA & GA - Loop B

## 9.4 Drawing Symbols

	<p><b>ACM-144</b> Exchange 230 VAC Mains 24 VDC Emergency Max. 138 Extensions</p>		<p><b>VMP-530</b> Main station <b>VML-1520</b> Loudspeaker 15W Options: <b>VMP-36-PEL</b> - Headset <b>IRR-3</b> - Relay unit <b>EHS-24</b> - Light signal</p>
	<p><b>IP Desk Master Station</b> Handsfree loudspeaking Alphanumeric call buttons 10 Direct Access keys Display with back-light Handset</p>		<p><b>VML-15T</b> Loudspeaker 100V / 15W  <b>JB15T</b> Junction box Deck areas, Staircases</p>
	<p><b>IP Flush Master Station</b> Handsfree loudspeaking Alphanumeric call buttons Display with back-light Handset</p>		<p><b>SAFE-10PT</b> Loudspeaker 100V / 10W  Bathrooms</p>
	<p><b>SPA-V2</b> Amplifier rack 230 VAC Mains 24 VDC Emergency 2 x SPA-120/240/400 2 x EE3 signal generator Mute contacts</p>		<p><b>CAR-4T or CAR-6T</b> Loudspeaker 100V 4 or 6W  Corridors</p>
	<p><b>SPA-AC6D</b> Alarm panel, dual system Abandon, general or manual alarms Alarm reset button Emergency button (EMS) for PA message</p>		<p><b>ACM-RJ45W-7</b> Junction box for IP Desk Master Station</p>
	<p><b>SPA-M6S</b> PA panel, single system Gooseneck microphone Pre-amp with level/tone 6 zone selection buttons ALL, TALK and dimmer buttons</p>		<p><b>Power over Ethernet</b> IP switch</p>
	<p><b>VMP-503</b> Main station  <b>VMP-211</b> Handset</p>		<p><b>Laptop/Personal Computer</b></p>
	<p><b>VMP-530 VHM</b> Main station in WT cabinet IP-54 w/int. microphone P66 noise cancelling mic  <b>VML-1520</b> Loudspeaker 15W</p>		<p><b>JUNCTION BOXES</b>  All junction boxes are yard supply</p>

# 10 Appendix B - ACM System Components

## 10.1 ACM Main System Racks

All system units will be marked with ID according to this list

Item number	Description	Function
3006204058	ACM-M-A-V2 System Rack	System rack
1150100002	ACM-M-D-V2 System Rack	System rack
1150100004	ACM-M-D/IP72 System Rack	IP based system rack for upto 72 devices
1150100006	ACM-M-D/IP96 System Rack	IP based system rack for upto 96 devices
3006204204	ACM-48-V10 System Rack	System rack
3006204202	ACM-144-V10 System Rack	System rack
3006204211	AACM-144-V10 System Rack	System rack
1009608000	AlphaCom XE7 server	Intercom exchange
1009621000	AlphaCom XE20 server	Intercom exchange
1009627000	AlphaCom XE26 server	Intercom exchange
1008095100	IP-ARIO	Audio Remote I/O Unit
2220050005	WS-C2960-24LT-L	Cisco 24-port low power PoE switch 100Mbit
2220050006	WS-C2960-24PC-L	Cisco 24port mid power PoE switch 100Mbit
1008131010	TKIS-1	Turbine Compact PCB
2030010260	AlphaCom Mains Transformer 6A	230 VAC to 24 VAC transformer for XE7
1009701000	AlphaCom AC power supply	Power supply for XE20 and XE26 exchanges
1009202100	AlphaCom AMC-IP processor board	Main processor board - intercom exchange
1009301000	AlphaCom APC board	Audio input card for XE20 and XE26 exchanges
1009101010	AlphaCom ASLT2 board	Conventional intercom line board
1009104000	AlphaCom ATLB-12 board	Analog telephone line board
1009303001	AlphaCom AGA board	Analog 0 dB audio interface board
1009304005	AlphaCom ASVP board	Stored voice playback board
1009511000	AlphaCom AMC-IP filter board with cable	AMC-IP filter board
1009501011	AlphaCom ASLT2 filter board with cable	ASLT2 filter board
1009501031	AlphaCom ATLB filter board with cable	ATLB filter board with cable
1009930300	AlphaCom Installation set program connection	AGA board program connection
1009503000	AlphaCom APC connection kit	APC connection kit
1009930200	AlphaCom ASLT connection board	Terminal module
1009930202	AlphaCom ATLB connection board	Terminal module
1009950100	Line Connection Module	Terminal module including relays
1009970200	AlphaCom MRBD multi relay board	Relay unit
1009970500	AlphaCom RIO unit	Remote I/O unit

## 10.2 ACM Field Equipment

All Field equipment will be marked with ID according to this list

<b>Analog intercom</b>		
<b>Order no.</b>	<b>Description</b>	<b>Function</b>
VMP-503	Main station, watertight	Conventional intercom
VMP-530	Main station, watertight	Conventional intercom
VMP-221	Wall mounted handset	Handset for VMP-503, VMP-530
VMP-211	Wall mounted handset	Handset for VMP-503, VMP-530
VMP-250	Wall mounted handset, watertight	Handset for VMP-503, VMP-530
VMP-36-PEL	Headset	Headset for VMP-503, VMP-530
VMP-36-PELP	Headset, portable	Headset for VMP-503, VMP-530
MT9	Throat microphone for headset	Headset VMP-36-PEL, VMP-36-PELP
VMP-503PA	Portable Intercom unit	Conventional intercom
VMP-503PA/15	Portable Intercom unit	Conventional intercom
1007095000	EX Intercom	Conventional intercom
VMP-619	Main station	Conventional intercom (desktop)
VMP-D619	Main station - display	Conventional intercom (desktop)
<b>IP intercom</b>		
<b>Order no.</b>	<b>Description</b>	<b>Function</b>
1008031000	IP flush master, display	IP intercom (console)
1008097100	Handset for IP flush master	Handset
1008097500	Gooseneck microphone	Gooseneck microphone for IP flush
1008010100	IP CRM V DAK module	Key (command) module for IP flush
1008001000	IP desktop master, display and handset	IP intercom (desktop)
<b>Analog telephones</b>		
<b>Order no.</b>	<b>Description</b>	<b>Function</b>
2213000300	VAF-1 Flush (console) mount analogue telephone, PA Call station	Analog telephone
2212000100	Desktop analog telephone	Analog telephone
2213000100	Heavy duty analog telephone	Analog telephone
2213000200	Heavy duty analog telephone with door	Analog telephone
P-290	Portable telephone	Analog telephone
HSB-03	Wall mounted watertight telephone	Analog telephone
HAS-3	Handset for wall mount analog telephone	Handset for HSB03
HAS-3WT	Handset for wall mount analog telephone	Handset for HSB03
P-MT7	Handset for wall mount analog telephone	Headset for HSB03
DA-24	Telephone EX, Zone 1, Watertight	Analog telephone
DA-24H	Telephone with headset EX, Zone 1, Watertight	Analog telephone

## Speakers, signal units, releayboxes, cabinets

Order no.	Description	Function
VML-1520	Horn speaker, 15W	Speaker 20 Ohm
DSP-15EExeN	EX horn speaker	Speaker 20 Ohm
VML-15T	Horn speaker, 15W	Speaker 100V
CL-200T	Ceiling loadspeaker	Speaker 100V
EHS-24	Signal lamp, 24V DC	Signal for intercom unit
EHS-220	Signal lamp, 220V AC	Signal for intercom unit
EHS-110	Rotary lamp, 110V AC	Signal for intercom unit
BLK5-24	Flash beacon, 24V DC	Signal for intercom unit
BLK5-220	Flash beacon, 220V AC	Signal for intercom unit
BLK5-115O	Flash beacon, orange115V AC	Signal for intercom unit
PD2100AC	Signal lamp w/lifeboat symbol 24V DC	Signal for intercom unit
A-100	Alarm horn, 24V DC	Signal for intercom unit
A-100AC	Alarm horn, 220V AC	Signal for intercom unit
HB-105	Telephone Tone Caller, 105dB	For analog telephone
HB-90	Telephone Tone Caller, 90 Db	For analog telephone
SON-16	Combined lamp, buzzer 24V DC	Signal for intercom unit
AL-1000	Combined lamp, buzzer 230V AC	Signal for intercom unit
AL-105N-WR-0	Combined lamp, horn 106dB 24V DC	Signal for intercom unit
CRB-7	Relay box, watertight	Relay for intercom unit
IRR-3	Relay box, watertight	Relay for intercom unit
PLM-32	Mounting cabinet	Cabinet for intercom unit
PLM-43	Mounting cabinet	Cabinet for intercom unit
PLM-54	Mounting cabinet	Cabinet for intercom unit
CD-4	Plugbox, watertight	For portable intercom unit
CD-7-VMP	Plugbox, watertight	For headset
SB01	Plugbox, watertight	For analog telephone P-290
PT-625A	Plugbox, indoor	For analog telephones
1009800100	Accessory kit	

# 11 Appendix C - Internal Power Wiring in System Racks

## 11.1 ACM-M-A-V2

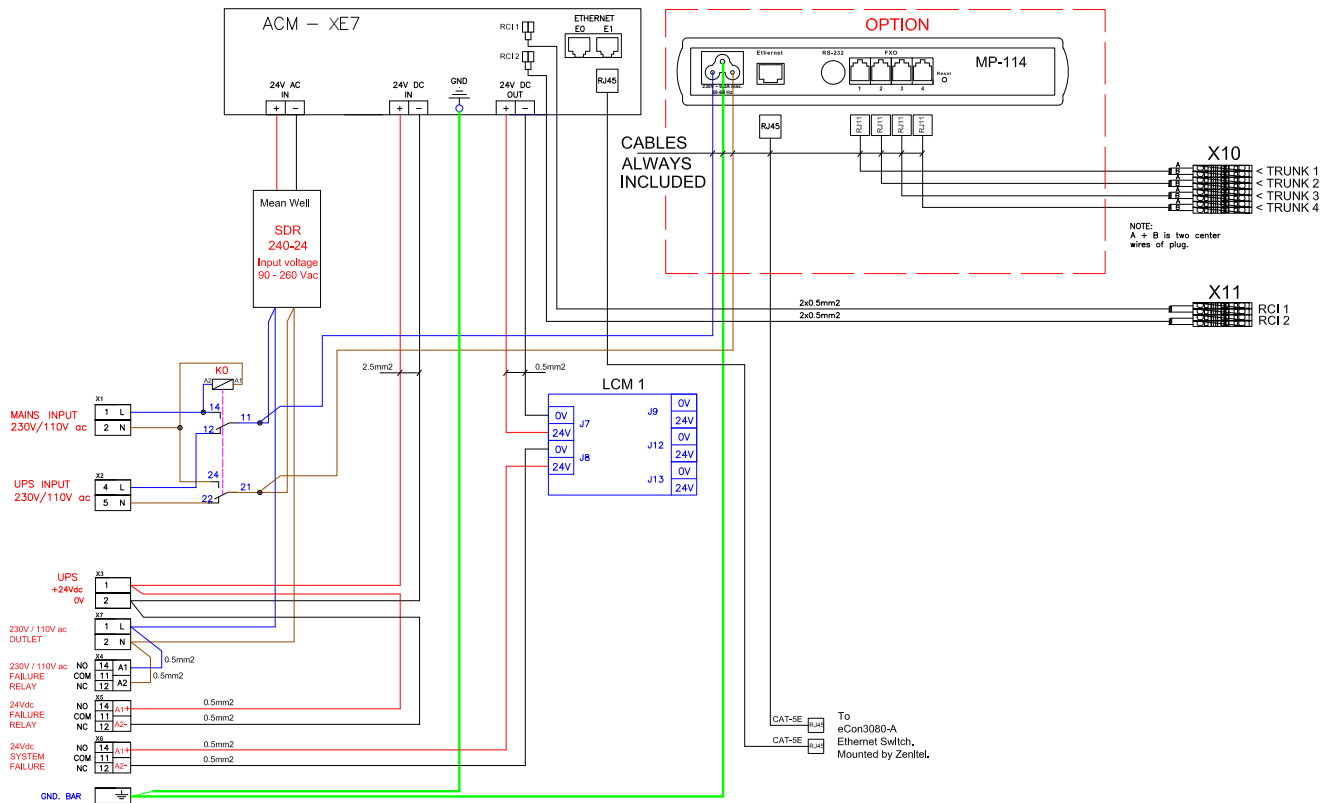

NOTES: IF NOT SPECIFIED OTHER TYPE, ALL WIRES=1.5MM2

- X1 - AC INPUT ISOLATOR (20A)
- X2 - AC INPUT ISOLATOR (20A)
- X3 - DC INPUT ISOLATOR (20A)

KO - Relay must be in accordance with voltage:  
 KO=FINDER 56.32.8.230.000-230Vac  
 KO=FINDER 56.32.8.110.000-110Vac

## 11.2 ACM-M-D-V2

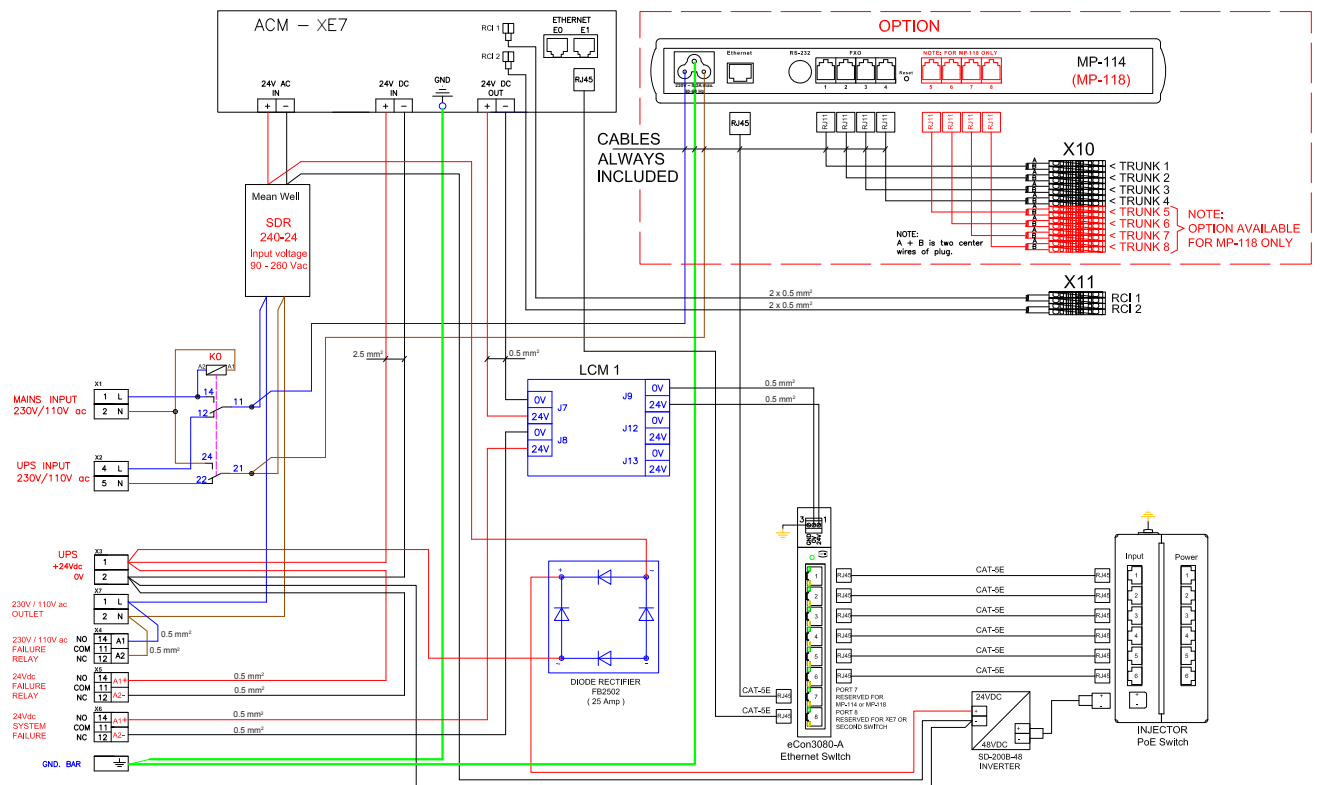

NOTES: IF NOT SPECIFIED OTHER TYPE, ALL WIRES=1.5MM2

- X1 - AC INPUT ISOLATOR (20A)
- X2 - AC INPUT ISOLATOR (20A)
- X3 - DC INPUT ISOLATOR (20A)

KO - Relay must be in accordance with voltage:  
 KO=FINDER 56.32.8.230.000-230Vac  
 KO=FINDER 56.32.8.110.000-110Vac

## 11.3 ACM-48-V10

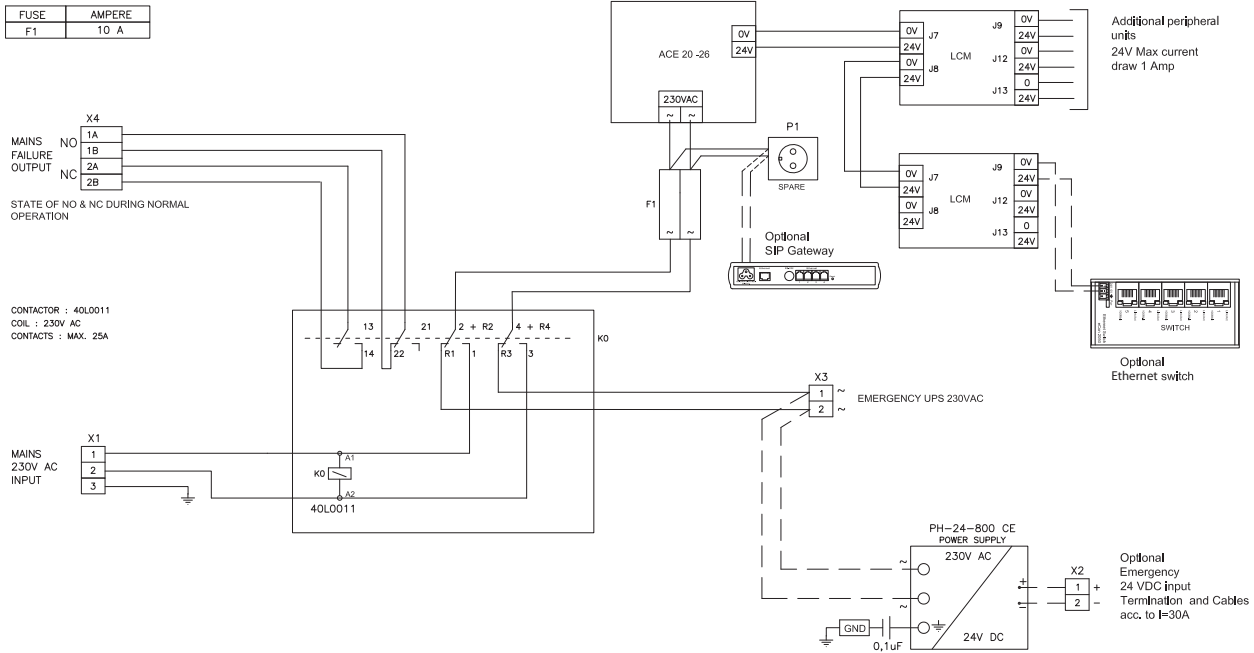

## 11.4 ACM-144-V10

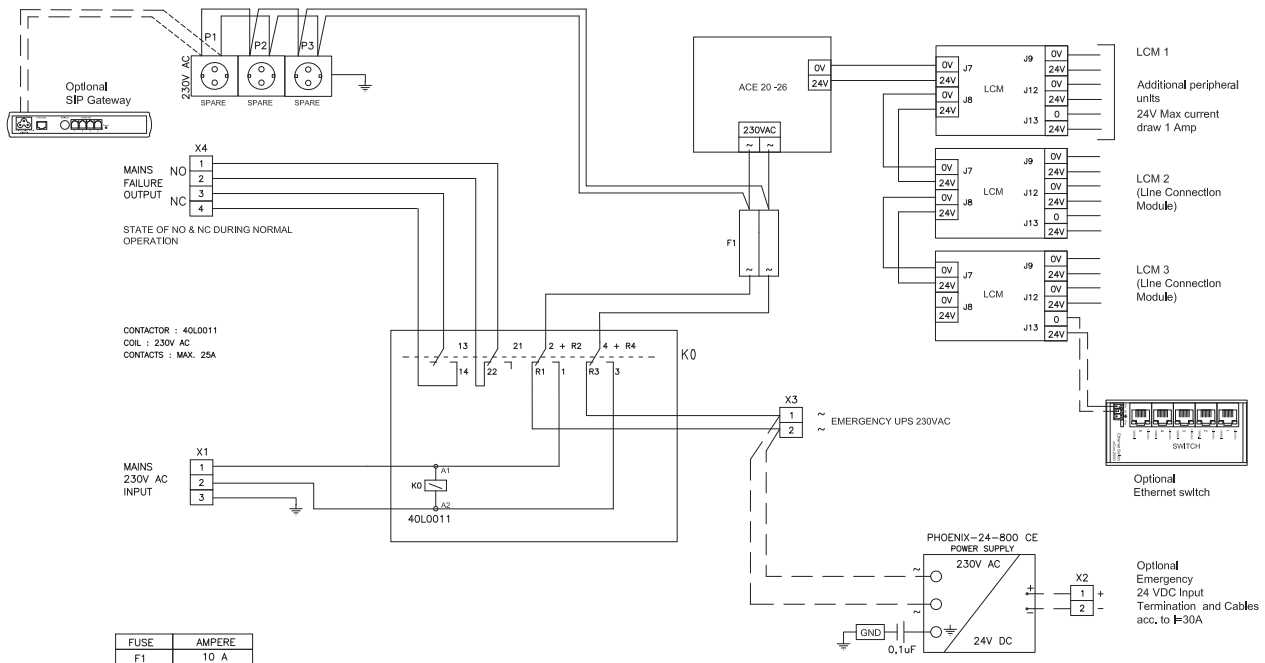



# 11.5 ACM-M-D/IP72

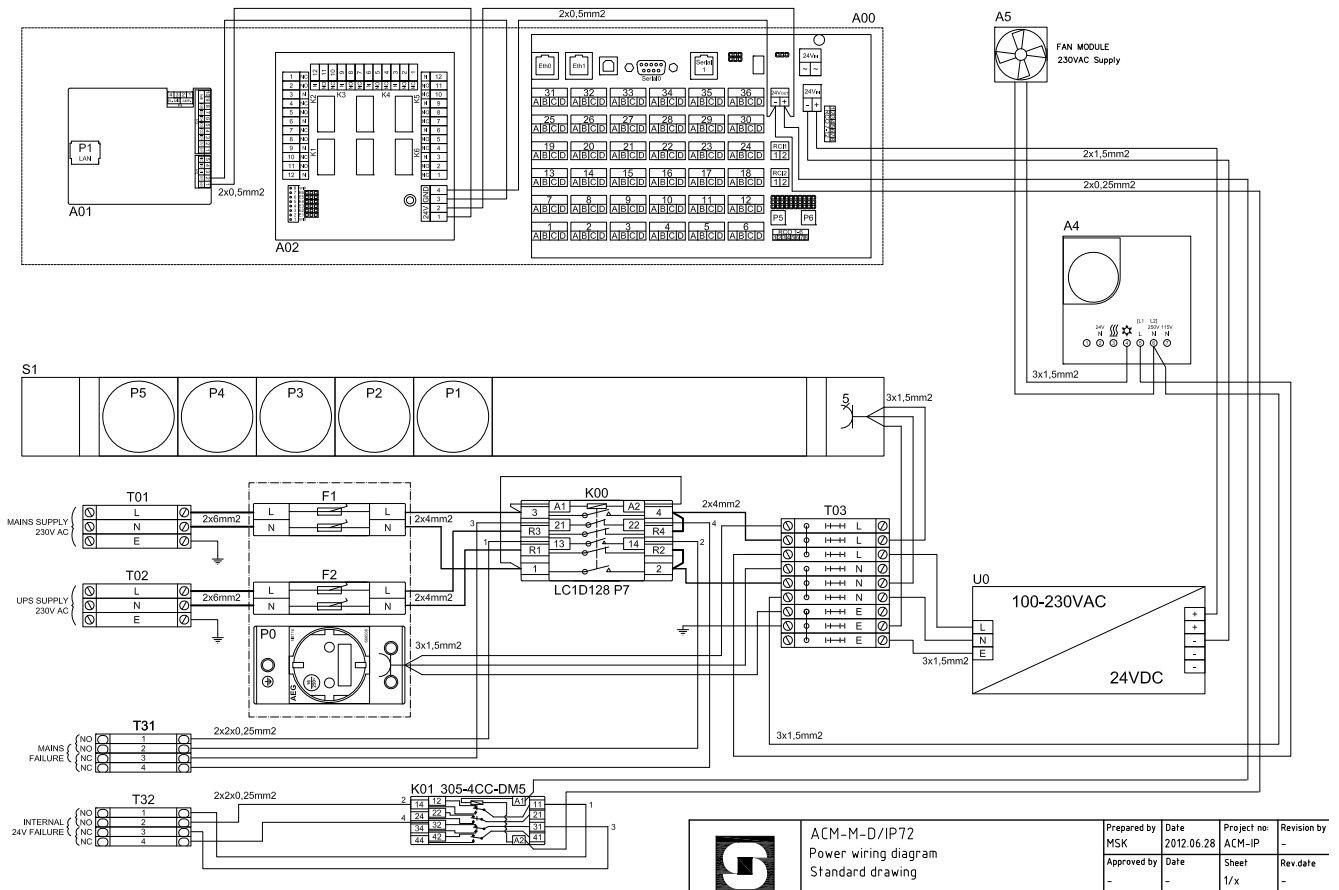

# 11.6 ACM-M-D/IP96

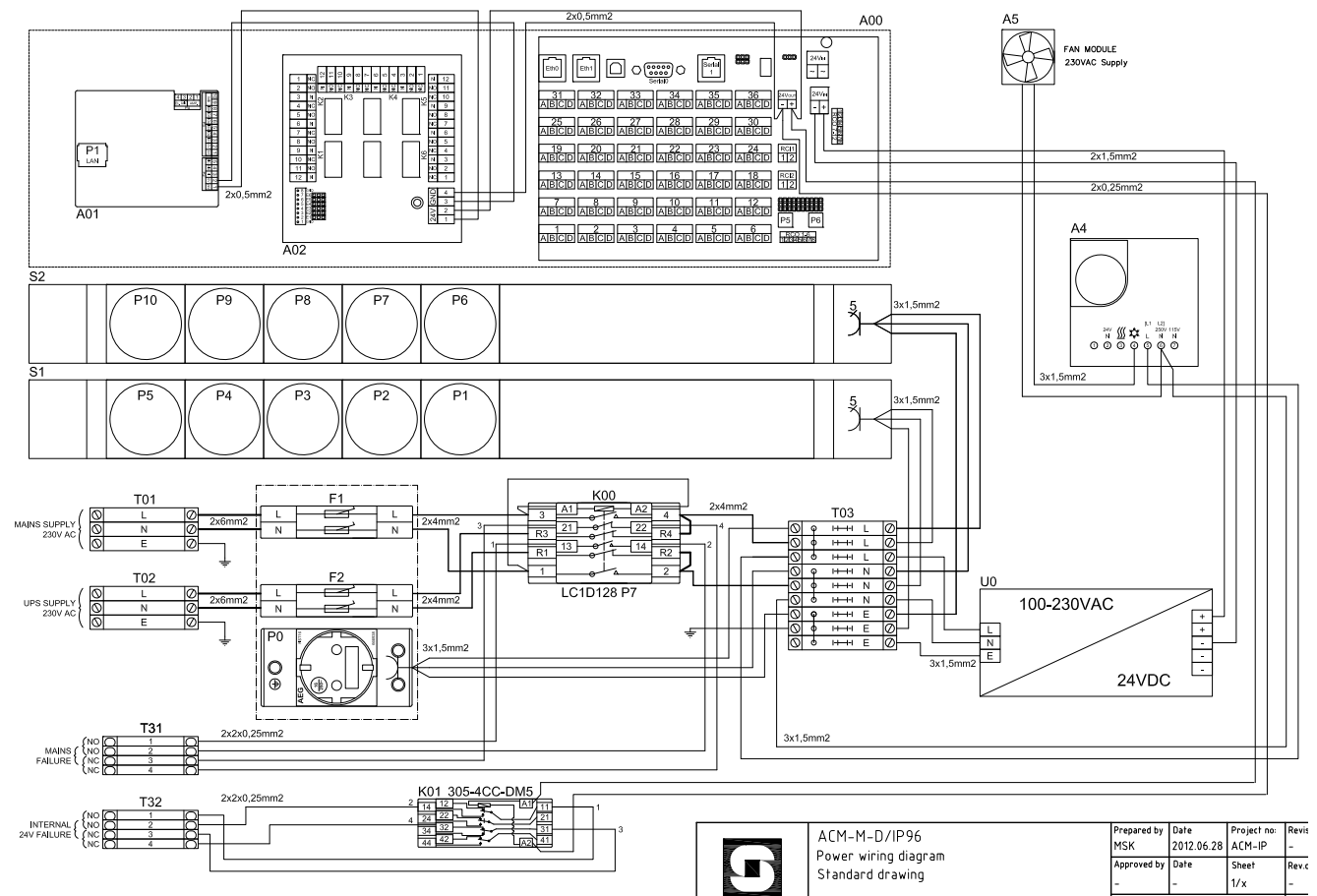

## 12 Appendix D - ACM Call Types

---

In order to fulfill our client's complex communication requirements onboard marine vessels, the ACM/AlphaCom system provides a set of different call modes.

- Through Connect Mode** allows calls between crew members to be instantly connected in loudspeaking mode. This full duplex method allows the crew to communicate without stopping the task at hand. In case the remote panel is in use at the time, the caller will receive a busy tone and will be automatically connected when the remote panel returns to idle.
- Ringling Mode** allows calls between crew members to be received as a ringling call to be answered by lifting the handset or pressing a key for clear sound and speech.
- Ringling Group Mode** allows calls to a ringling group consisting of multiple crew stations. All crew panels will ring, allowing the call to be accepted at any crew panel.
- Call Request Mode** is the default mode for Talk-Back members calling to the Bridge. Talk-Back members are informed with a message that their call is in a queue, and the Bridge is notified with a buzzer, flashing button LED and call queue in the display.
- Group Call Mode** is the default method for accessing the Public Address system. Each zone on the set is defined as a group, and multiple groups may be selected by the crew for addressing. Group calls begin with an announcement 'Ding Dong', and the crew must use Push-to-Talk to broadcast their messages.
- Push-To-Talk Conference** is the default method for Talk-Back and accessing radio systems. Operators manage their access to the conference using the Push-To-Talk key.
- Open Duplex Conference** is a conference providing audio mixing between multiple participants. In an open duplex conference, the users do not need to use Push-to-Talk keying.

## 13 Appendix E - Audio Messaging

The Audio Messaging features are used to provide various messaging services and PA broadcast in the AlphaCom XE Audio Server. The messages are pre-stored in flash memory on the main processor board and can be played back to individual stations or a group of stations to provide information such as:

- Voice guidance at doors and elevators
- Security voice response
- Auto-Attendant and voice guidance
- Information messages
- Alarm and evacuation messages

There are four ways to implement audio messaging services in the AlphaCom XE:

- ASVP software module
- ASVP board
- Upload customized WAV files from AlphaWeb
- Record customized messages from an intercom station

**ASVP = AlphaCom Stored Voice Playback**

### 13.1 Stored Voice Messages

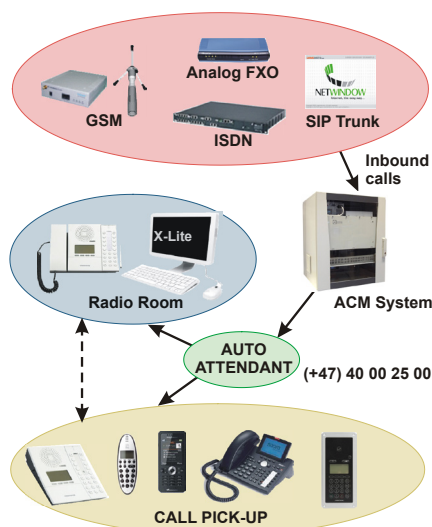

Both the Basic and the Enhanced Audio Messaging licenses have the capability of storing and playing audio messages from the Alphacom XE server. The feature set of the license is compatible with that of the ASVP board but offers some important additional functionalities.

The audio messaging license offers a broad set of applications and functions, some of which are:

- Live PA and group call broadcast with recall for handling feedback and verifying messages
- Pre-stored PA and group call broadcast
- Scheduled or event-based PA and group call broadcast
- Auto-Attendant with voice guided menus for handling incoming calls
- Voice response for 'call request waiting' messages and absence messages
- Integration with 3<sup>rd</sup> party systems via OPC, STENTOFON SDK and STENTOFON Data Protocol

When the Audio Messaging license is activated, the Alphacom XE server will have a set of default messages such as absence, alarm and general information messages. The default messages can be changed and new messages can be added. Both new and modified messages can be recorded from an intercom station or created on a PC. Your favorite audio and music programs can be used to create these messages, which can then be uploaded to the Alphacom XE server via AlphaWeb.

The audio messaging license comes in three versions – Basic, Enhanced, and PA Recall. The licenses are different in terms of:

- Audio storage capacity
- Set of default audio messages
- Interactive complex message generation (Enhanced License only)
- Compatibility with hardware versions

### 13.1.1 Message identification

Stored Voice Messages are reached by a combination of two numbers: Message Group and Group Index.

The AMCD application uses this reference as the starting point when a message shall be played back. The same references are used for display texts to be looked up from the Message Description File.

### 13.1.2 ASVP software module

The ASVP module and the ASVP board support composing a voice message in run-time by using sequences of voice files and also composing parameterized messages.

Parameterized messages can be used to pronounce numbers, dates and times from the SW control. A Message Group/Index reference will result in playback of a sequence of WAV files

A set of standard audio messaging services can be implemented by uploading a language package file to AlphaCom XE using the web interface, AlphaWeb. The standard messages comprise:

- Absence messages
- Information messages
- Help messages
- Alarm messages

The types of messages that actually become available depend on the installed Audio Messaging license.

#### Install language package

The language file has the format **asvp\_xx\_06.00.apkg**, where **xx** is the actual language and **06.00** is the version number.

Before the installation can start, you need to download the language file from Zenitel's support websites **AlphaWiki** or **Partnetnet** to your PC.

- In AlphaWeb, select **System Maintenance > System Upgrade**
- Click **Browse** to choose the language file and click **Upload**
- Click the **Install** button

The messaging services becomes available immediately after the installation. No reset is required.



*Note that:*

- It is only possible to install a single ASVP package at a time.
- When installing a new version of the same package, just install over the old one.
- When installing a different ASVP package, delete the old ASVP package first.

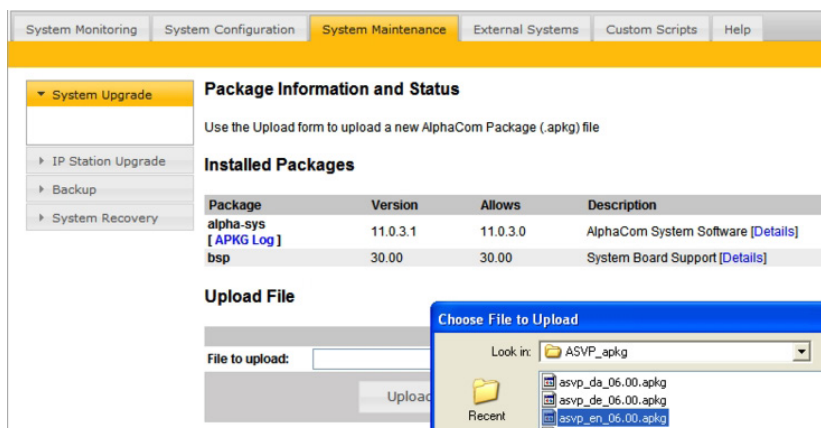

### 13.1.3 ASVP board

The ASVP board has been discontinued and replaced by the ASVP Software Module.

The ASVP board has the same set of standard messages as the ASVP Software Module.

No configuration is required when the ASVP board is used. Insert the board in any free board position in the AlphaCom server and the messaging services will be automatically activated when the system is powered up.

① *The ASVP board does not require any license.*

## 13.2 Customized Message Upload

The ASVP software module provides the AlphaCom XE server with a set of default messages such as absence, alarm, and general information messages.

It is possible to modify or add new messages to the system by uploading audio files to the AlphaCom XE server using AlphaWeb.

- If the ASVP Software Module is present, a web loaded message will mask the corresponding ASVP message.
- Deleting the web loaded message will unmask the ASVP message.

An Easy Message is one single WAV file for each Message Group + Group Index.

- Web-loaded messages are uploaded individually via AlphaWeb
- Station-recorded messages are recorded from a station

The audio file can be recorded on a PC or in a professional studio if high quality playback is required. The audio file must be in WAV format.

The following codecs are supported:

- PCM files at 16kHz sample rate (linear 16bit), mono (1 channel)
- MS ADPCM at 16kHz sample rate, mono (1 channel)
- IMA ADPCM at 16kHz sample rate, mono (1 channel)

When a request is made to AlphaCom XE to play a message, it will search for matching group/index in the following order:

1. Station-recorded message
2. Web-loaded message
3. Message in the ASVP Software Module on the AMC-IP board
4. Message on the ASVP board (if present)

### 13.2.1 Upload messages from AlphaWeb

When uploading a WAV file, the file must be associated with the relevant intercom feature by means of two parameters: **Message Group** and **Group Index**.

In the tables below, you can find the link between the intercom feature and the Message Group and Group Index for the message you intend to customize.

- Log on to AlphaWeb
- Select **System Configuration > Messaging**
  - An Audio Messaging license must have been installed up front to be able to access this page.
- Go to the **Upload Wav File** section at the bottom of the page, and select **Message Group** and **Group Index** according to the tables below.
- Browse to the WAV file, and select **Upload**.

The file will now be renamed and stored on the flash memory on the AMC-IP card.

**Custom Audio Message Files:**

Search:  Display 15 records

File Name	Size (kB)	Modified Date	Message group (Index)	Related Dirno	Action
[svp_010_047.wav]	126.4	2010-06-22 15:33:06	(10)Help message (47)		[Select for upload] [Delete]
[svp_030_001.wav]	407.6	2010-06-22 15:29:28	(30)Announcement message (1)	8191 MessageFire	[Select for upload] [Delete]

Showing 1 to 2 of 2 entries

Free space for Wav files: 10240kB

**Upload Wav File:**

Message Group	Group Index	File To Upload
(30)Announcement message	2	vav files\FireAlarm_en.wav <input type="button" value="Browse..."/>

*Example:*  
**svp\_030\_001.wav**  
 is group 30, index 1,  
 (Alarm message 8191).

The file name will be renamed to **svp\_ggg\_iii.wav** where **ggg** is the Message Group number and **iii** is the Group Index number.

- Select the **System Configuration > Messaging** page to see and listen to all uploaded WAV files. Any file may be deleted.

There are no restrictions on the messages that can be uploaded but the message is checked against the installed Audio Messaging license to see if it is available for playback.

The most relevant English messages are listed below.

VOICE GUIDANCE AND INFORMATION MESSAGES					
Dir. no.	Feature	Message Group	Group Index	Default English ASVP message	Minimum license required
9550	Auto-Attendant	11	1		Basic: 1 Enhanced: 3
622 or 623	Send Call Request	10	47	"Your call is registered, please wait."	None
70	Station reset	10	42	"No messages."	None

ALARM MESSAGES					
Dir. no.	Feature	Message Group	Group Index	Default English ASVP message	Minimum license required
8191	Alarm Message 1	30	1	"Fire alarm. Please stay calm and leave the building through the nearest exit. All exits are marked with green light. Don't stop, but proceed completely out of the building. Wait for further information outside."	Basic
8192	Alarm Message 2	30	2	"The situation is now under control, the building can again be used. We are sorry for the inconvenience."	Basic
8193	Alarm Message 3	30	3	"An unexpected situation has occurred. Please stay calm and leave the building through the nearest exit. All exits are marked with green light. Don't stop but proceed completely out of the building. Wait for further information outside."	Basic
8194	Alarm Message 4	30	4		Enhanced
8195	Alarm Message 5	30	5		Enhanced
8196	Alarm Message 6	30	6		Enhanced
8197	Alarm Message 7	30	7		Enhanced
8198	Alarm Message 8	30	8		Enhanced
8199	Alarm Message 9	30	9		Enhanced

### 13.2.2 Record message from a station

It is possible to modify or add new audio messages from a Super User station. The default directory number for the recording function is **8180**.

The best result is achieved by using a station with handset for the recording.

### **Recording procedure:**

1. Dial **8180 + the directory number** of the feature that you want to modify
  - If a message already exists, the message will be played back.
  - If the message is a station-recorded message, it has to be deleted by pressing digit **0 + M-key** before a new message can be recorded
2. Press the **M-key** to start recording.
  - Each M-key press starts a new recording
3. Release the **M-key** to stop recording
  - The recorded message is played back
4. Press **digit 7** to listen once more to the message
5. Press **digit 8** to store the message
6. Press the **C-key** to cancel the recording without storing the message

<b>SOME FEATURE EXAMPLES</b>		
<i>Dial</i>	<i>Feature</i>	<i>Minimum license required</i>
8180 + 9550	Auto-Attendant	Basic: 1 Auto-Attendant Enhanced: 3 Auto-Attendants
8180 + 623	Send Call request	None
8180 + 70	Station reset	None
8180 + 8191-8199	Alarm Message 1-9	Basic: 3 alarm messages Enhanced: all alarm messages
8180 + 771-779	Absence messages	Enhanced
8180 + 660-669	Voice Mail messages	Enhanced

A station-recorded message will mask any corresponding web-loaded message or ASVP message. When a station-recorded message is deleted, the web-loaded message will be unmasked if present.

A station-recorded message will be stored as a WAV file in the flash memory of the AMC-IP board and can be accessed from the **System Configuration > Messaging** page in AlphaWeb.

The WAV file will be stored with the file name **svp\_ggg\_iiaa\_wav**, where **ggg** is the Message Group number, **iii** is the Group Index number and **a** indicates that it is a station-recorded message and not a web-loaded message.

You are only allowed to record messages according to the type of Audio Messaging license installed.

To be able to carry out station recording, the station must have access to features 111 and 114 in its Class of Service settings.

*Example:*

**svp\_030\_001a.wav**

shows that this is a station-recorded message associated with group 30 and index 1. (Alarm message 8191).

### **13.2.3 Licensing**

Playback of Stored Voice Messages stored on the AMC-IP board requires a license.

Usage of the ASVP board requires no license.

The license check is done on the Message Group/Index number at the time a message is requested for playback. Different message groups are used for different functions, hence, blocking per function as well as limiting the number of different messages for a function is possible.

Licenses does not limit the duration of single messages or the total duration of all stored messages.

Upload of Easy Messages and Station Recording features are not restricted by license. The ASVP module is also active without any license. The licensing only blocks the messages that can be used.

- **No license**

- Only ASVP help messages are available (Message Group 10)
- Standard ASVP messages by uploading ASVP Software Module
- Record own customized messages

- **PA Recall license** (works on AMC-IP v. 10 or 11 hardware)
  - Delayed group call to prevent feedback
- **Basic Messaging license** (requires AMC-IP v. 11 hardware)
  - ASVP help messages (Group 10)
  - 1 Auto-Attendant message ( Message Group 11, index 1)
  - 3 Voice Alarm Messages 8191-8193 (Message Group 30, index 1-3)
  - Recall function. Delayed group call to prevent feedback
  - Up to 2 Mbyte customized WAV files (approx. 4 min. 16 sec. speech)
- **Enhanced Messaging license** (requires AMC-IP v. 11 hardware)
  - Unlocks all current messaging features
  - ASVP help messages (Message Group 10)
  - 3 Auto-Attendant messages (Message Group 11, index 1-3)
  - Any number of Voice Alarm Messages (Message Group 30)
  - Up to 10 Mbytes of customized WAV files (approx. 21 min. 20 sec. speech)
  - Recall function. Delayed group call to prevent feedback
  - Absence Messages (771 - 779)
  - Mail Messages (660 - 669)

### 13.2.4 Supported audio file formats

AlphaCom can only play back WAV container file format with 16kHz sample rate, single channel (mono), and one of the following three encodings

- PCM files at 16kHz sample rate (linear 16bit), mono (1 channel)
- MS ADPCM at 16kHz sample rate, mono (1 channel)
- IMA ADPCM at 16kHz sample rate, mono (1 channel)

PCM files need 32 KByte/s. The ADPCMs need 8 KByte/s (same as G.711/G.722).

Station-recorded Easy Messages are stored as IMA ADPCM.

## 13.3 Recall

The Recall function lets you record a message from a station and then dispatch the recorded message as a Group Call.

- The function is used to prevent feedback problems when making Group Calls
- The recorded message is stored temporarily
- It is deleted when the group call is finished
- The maximum duration of a single recall message is limited to 3 minutes
- The total system storage capacity for recall is approx. 40 minutes

### 13.3.1 Directory numbers

The default directory numbers for “recall” broadcast are:

- 9084: Recall to group 1 (all)
- 9085-9088: Recall to groups 2 - 5
- 9101: Recall to global group 1 (for AlphaNet)

More recall numbers can be added from AlphaPro if required:

- In the **Directory & Features** window, select **Insert**
- Select **Group Call w/Recall - 113** from the **Feature** drop-down list
- Enter the local group number in the **ID** field
- Enter any free directory number and an appropriate display text in the **Directory Number** and **Display Text** fields.



The recall function can also be activated via a two-step operation using feature code 765:

- Dial 765 + group number.

### 13.3.2 User interface

#### Using the recall function from an intercom station

1. Dial the **recall number** (e.g. 9084 or 765+84)
2. Press the **M-key** to record a message
3. Release the **M-key** to listen to the recording
4. Press **8** to dispatch the message or:
  - Press the **M-key** to make a new recording
  - Press **7** to repeat the message
  - Press the **C-key** to cancel the message

#### Using the recall function from a telephone

1. Dial the **recall number** (e.g. 9084 or 765+84)
2. Press the **\*-key** to record a message
3. Press the **#-key** to stop the recording and listen to the message
4. Press **8** to dispatch the message or:
  - Press **\*** to make a new recording
  - Press **7** to repeat the message
  - **Hang up** to cancel

### 13.3.3 Optional settings

The recall user interface and the recall attributes can be altered by modifying parameter 2 (set in AlphaPro) of the recall directory number. By default, this parameter has value 0.

RECALL OPTIONS	
Value parameter 2	Function
1	After playback to the group has finished, the group call and the initiator station will proceed to normal Group Call mode, and can use the M-key to talk into the group
2	If the initiator station disconnects during playback to the group, the message is terminated immediately
8	The initiator station will not listen to the playback to the group
32	The message is dispatched when pressing the C-key or hanging up (no need to confirm by pressing 8)
128	There will be no gong before the group call
256	The group is a global group call
512	There is no need to use the M-key during the recording

Parameter 2 can be modified to change the recall user interface and different options can be combined.

#### **Example:**

If parameter 2 = 544 (i.e. 512+32), there will be no need to press the M-key to record and the message is dispatched when pressing the C-key. This option can be useful when using the recall function from telephones.

1. Dial the **recall number** (e.g. 9084)
2. Record message (no M-key)
3. Press the **C-key** or hang up to dispatch the message or:
  - Press **7** (or **#**) to stop the recording and listen to the message
  - Press the **M-key** (or **\***) to restart a recording

- Press **0** to delete the recording and cancel the operation

For two-step recall (i.e. 765 + group), the attributes are set in parameter 1 (ID) of the 765 feature code.

### 13.3.4 Simultaneous recall operations

Simultaneous recall operations are handled in the same way as for regular group calls.

Several recall operations can be active at the same time as long as there is no overlap in members of the simultaneous groups. If there is an overlap, the second recall operation will meet a busy signal.

There is a “Max Missing Members” setting per group in AlphaPro, which will let the second group call go through if the overlap is less than the number of stations specified.

#### Disable simultaneous group calls in AlphaPro

- Select **Exchange & System > System > Calls and Options**
- Disable **Simultaneous Group Calls** by unchecking the box
  - only one group call can be active at a time

Each group call can be assigned one out of four available **Setup Priority** levels.

#### With Simultaneous Group Calls

- A group call is canceled by a group call with higher priority if there is overlap between members.

#### Without Simultaneous Group Calls

- An ongoing group call is canceled by a group call with higher priority.

### 13.3.5 Hardware and software requirements

- **Hardware:** The recall function can be used on AMC-IP board versions 10 (red PCB) and 11 (black PCB).
- **Software:** Recall is available from AMC-IP software version 11.
- **License:** Recall requires an Audio Messaging license.

## 13.4 Auto-Attendant

The Auto-Attendant feature provides voice guided menus for handling incoming calls.

- Play a welcome message on incoming telephone calls
- Press a digit to re-route the call
- If no digits are pressed, the call will be automatically re-routed 5 seconds after the message has finished playing

The Auto-Attendant feature is also available for internal calls and is not restricted to external calls only.

### 13.4.1 Configuration

The default directory number for the Auto-Attendant feature is 9550.

#### Recording the message

- Dial **8180 + 9550** from a Super User station.
  - Press and hold the **M-key** while recording.
- Release the **M-key** to listen to the message
  - Press **8** to save, or
  - Press the **M-key** again to make a new recording

Alternatively, a WAV file can be uploaded from the web interface, AlphaWeb as described in section 9.2.1.

### Digit routing

The Auto-Attendant number 9550 uses the DAK table of physical station 500 for the “digit” actions.

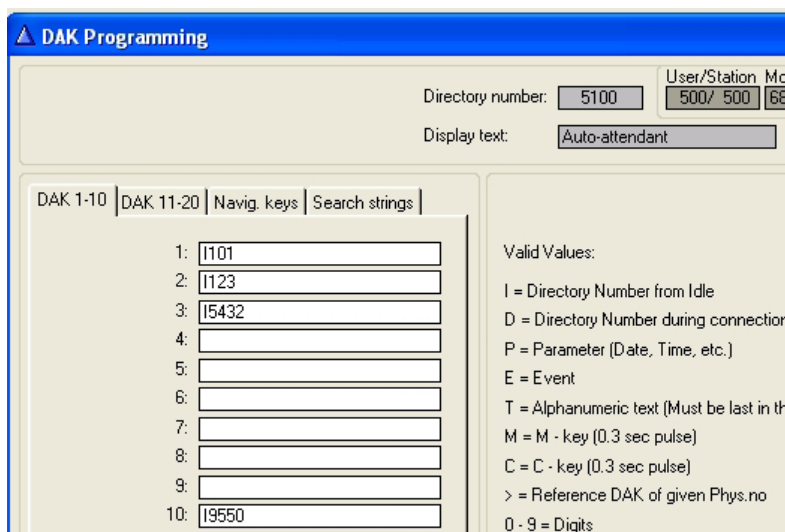

- In the **Users & Stations** window in AlphaPro, select physical number **500** in the list box and click **DAK**
- In the DAK table, enter the call destination for digit 1 to 9 (DAK 1-9), and digit 0 (DAK 10)

If the caller doesn't press any numbers within 5 seconds, the call is automatically routed to the entry in Search String 1.

In the Auto-Attendant digit routing example shown, Digit 1 calls station 101, digit 2 calls station 123, digit 3 calls station 5432, and digit 0 repeats the voice menu

### Adding more Auto-Attendant numbers

Up to 3 Auto-Attendant numbers are supported, depending on the license installed. Directory numbers for the first Auto-Attendant is included by default. For the second and third Auto-Attendants, you have to add new directory numbers from AlphaPro.

### Adding a second Auto-Attendant

In **Directory & Features**, click **Insert** and add a new number with the following properties:

Dir. no.	Display Text	Feature	Parameter 1 (User no.)	Parameter 2	Parameter 3	Description
9551	AutoAttendant2	105	0	2	501	Auto-Attendant number 2, using Stored Voice Message 2 and the DAK table of physical number 501

- To record a message, dial **8180 + 9551 + M-key**. Digit routing is done in the DAK table of physical number 501.

### Adding a third Auto-Attendant

- In **Directory & Features**, click **Insert** and add two new numbers with the following properties:

Dir. no.	Display Text	Feature	Parameter 1 (User no.)	Parameter 2	Parameter 3	Description
8183	MenuMsg3	111	11	3	0	Stored Voice Message 3
9552	AutoAttendant3	105	0	3	502	Auto-Attendant number 3, using Stored Voice Message 3, and the DAK table of physical number 502

- To record a message, dial **8180 + 9552 + M-key**. Digit routing is done in the DAK table of physical number 502.

## 13.4.2 Hardware and license requirements

- **Hardware:** The Auto-Attendant feature requires AMC-IP hardware version 8000/5 or 8000/6 (Black PCB).
- **License:** Auto-Attendant requires a Basic (1 Auto-Attendant) or Enhanced (3 Auto-Attendants) Audio Messaging license.

